

NAPOLEON[®]
FIREPLACES
COM



Grandville™ 36 CF shown with standard clean face front, multi-color River Rock media kit and MIRRO-FLAME™ Porcelain Reflective Radiant Panels.

AVAILABLE NOW



GRANDVILLE™ 36 CF

DIRECT VENT GAS FIREPLACE



For more information or to place an order call 1-800-461-5581 or visit napoleonfireplaces.com

Grandville™ 36 CF

Napoleon's popular modern 36" fireplace is available as a clean face unit with a louver-free view of the firebox. The heat radiating glass, beautiful display of **YELLOW DANCING FLAMES™**, realistic **PHAZER™** log set make it a perfect complement to a crisp, contemporary design with plenty of reliable, cozy heat. The perfect fireplace for those wanting a traditional look but a clean face contemporary design, the Grandville™ 36 CF gives you the best of both worlds.

Product Features

- Up to 17,000 BTU's
- Available in natural gas and propane
- Standard safety screen
- Hideaway door allows easy access to the hidden control panel
- Built-in adjustable flame and heat control
- Heavy gauge steel pan burner creates a real fire experience
- PHAZER™ log set, replicates a natural wood burning look
- Back-up control systems ensures reliable use, even during power failures
- Available in either millivolt or electronic ignition control system
- Equipped with 100% **SAFE GUARD™** gas control system
- Optional **MIRRO-FLAME™** Porcelain Reflective Radiant Panels
- Optional convenient remote controls
- Optional heat circulating blower
- Optional River Rock kits are available to switch out the existing log set for a more contemporary look



Features/Options/Accessories



River Rocks available in Grey or Multi-colored



MIRRO-FLAME™ Porcelain Reflective Radiant Panels



Convenient Remote Control

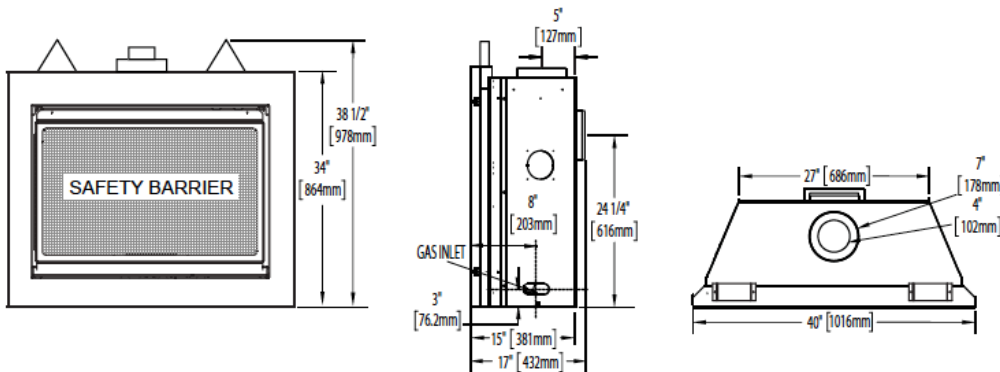

Napoleon®, leaders in design & technology have developed safety screens with aesthetically pleasing designs for every gas appliance to ensure ultimate safety and peace of mind for your family.

Product Code	BTU's (Input)	Top/Rear Venting	Height		Width		Depth		Glass Size		Efficiency
			Actual	Framing	Actual	Framing	Actual	Framing	Height	Width	EnerGuide
BGD36CFNTRSB	17,000	4" x 7"	34"	42 1/4"	40"	40 1/2"	15"	17 1/4"	19"	31 1/4"	59.4%

Certified under Canadian and American National Standards
 Figures may vary with individual conditions such as floor plan layout, insulation value/heat loss of the house and geographical location.

Consult your owner's manual for complete installation instructions, accurate framing dimensions and proper clearances to combustible material. Check all local and national building codes and gas regulations. All specifications are subject to change without prior notice due to on-going product improvements. Products may not be exactly as shown. Napoleon® is a registered trademark of Wolf Steel Ltd. © Wolf Steel Ltd.



24 Napoleon Road, Barrie, Ontario, Canada L4M 0G8
 103 Miller Drive, Crittenden, Kentucky, USA 41030
 7200 Trans Canada Highway, Montreal, Quebec, Canada H4T 1A3
 Tel: 705-721-1212 Fax: 705-722-6031
 napoleonfireplaces.com

Authorized Dealer

