

INSTALLER: LEAVE THIS MANUAL WITH THE APPLIANCE.
CONSUMER: RETAIN THIS MANUAL FOR FUTURE REFERENCE.

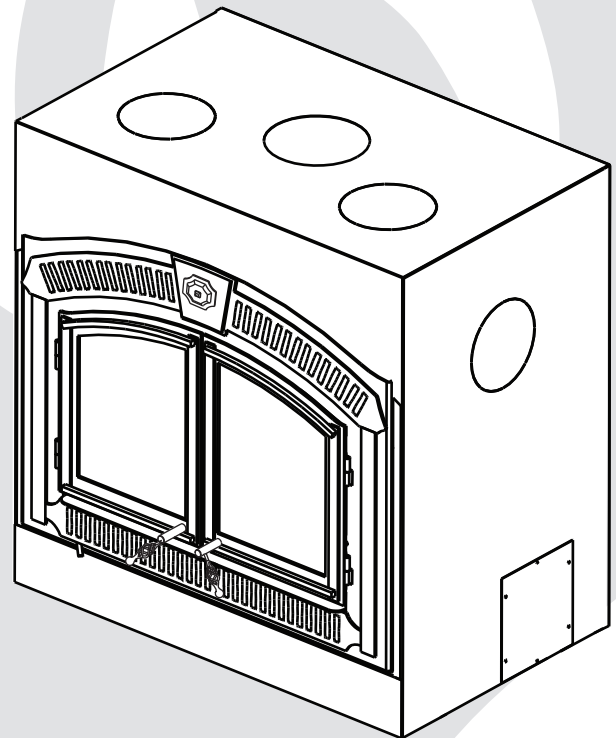

INSTALLATION AND OPERATING INSTRUCTIONS

THIS FIREPLACE HAS BEEN TESTED AND LISTED BY INTERTEK TESTING SERVICES LTD. AS PER THE STANDARDS: CAN/ULC S610, UL 127 FOR FACTORY BUILT FIREPLACES AND TO ULC S639 FOR STEEL LINER ASSEMBLIES FOR SOLID FUEL BURNING MASONRY FIREPLACES. CERTIFIED UNDER USA ENVIRONMENTAL PROTECTION AGENCY (EPA).



SAFETY INFORMATION

WARNING

If the information in these instructions are not followed exactly, a fire or explosion may result causing property damage, personal injury or death.

Please read entire manual before you install and use your heater.

This heater has not been tested with an unvented gas log set. To reduce risk of fire or injury, do not install an unvented gas log set into the heater.

- This heater can be very hot when burning.
- Combustible materials such as firewood, wet clothing, etc. placed too close can catch fire.
- Children and pets must be kept from touching the heater when it is hot.
- The chimney must be sound and free of cracks. Before installing this unit, contact the local building or fire authority and follow their guidelines.
- Operate only with the doors tightly closed.
- Burn wood behind the log retainer directly on the firebricks.
- Do not use an elevated grate or otherwise raise the fire.
- This heater is designed to burn natural wood only. Higher efficiencies and lower emissions generally result when burning air dried seasoned hardwoods, as compared to softwoods or to green or freshly cut hardwoods.
- Do not start a fire with chemicals or fluids such as gasoline, engine oil, etc.
- Do not burn treated wood, coal, charcoal, coloured paper, cardboard, solvents or garbage.
- Do not let the heater become hot enough for any part to glow red.



APPLY SERIAL NUMBER LABEL FROM CARTON



Wolf Steel Ltd., 24 Napoleon Rd., Barrie, ON, L4M 4Y8 Canada /
103 Miller Drive, Crittenden, Kentucky, USA, 41030
Phone (705)721-1212 • Fax (705)722-6031 • www.napoleonfireplaces.com • ask@napoleon.on.ca

TABLE OF CONTENTS

1.0	INSTALLATION OVERVIEW	3
2.0	INTRODUCTION	4
2.1	DIMENSIONS	5
3.0	GENERAL INFORMATION	5
3.1	FEATURES	6
3.2	HEATING SPECIFICATIONS	6
3.3	ELECTRICAL SPECIFICATIONS	6
3.4	PACKING LIST	6
3.5	CALIFORNIA PROP 65	6
3.6	EPA COMPLIANCE	6
3.7	RATING PLATE INFORMATION	7
3.8	CARE OF GLASS	7
3.9	HI-EFFICIENCY HEATING	8
3.9.1	HOT AIR GRAVITY VENT SYSTEM (NZ220)	8
3.9.2	CENTRAL HEATING SYSTEM (NZ62CH)	9
3.9.3	BLOWER CIRCULATION (NZ64)	9
4.0	INSTALLATION PLANNING	10
4.1	LOCATION AND CLEARANCES	10
4.2	COMBUSTION AIR	11
4.3	EMBER STRIP AND HEARTH EXTENSIONS	12
4.4	HEARTH EXAMPLES	13
4.5	MINIMUM CLEARANCE TO COMBUSTIBLES	14
4.6	MINIMUM CLEARANCES TO COMBUSTIBLE ENCLOSURES	14
5.0	CHIMNEY INSTALLATION	15
5.1	ADDING CHIMNEY SECTIONS	17
5.2	OFFSET CHIMNEY INSTALLATION	18
5.3	INSTALLING FLASHING AND STORM COLLAR	19
5.4	CONNECTION TO A MASONRY CHIMNEY	19
6.0	APPLIANCE INSTALLATION	20
6.1	FRAMING	20
6.2	FINISHING	21
6.3	ENCLOSURE VENTILATION	22
6.4	MINIMUM MANTEL CLEARANCES	23
7.0	FINISHING	24
7.1	BAFFLE AND INSULATION BLANKET INSTALLATION	24
7.2	FACE PLATE, UPPER GRILLE, KEYSTONE AND DOOR INSTALLATION	25
7.2.1	FACEPLATE, HINGE, ASH LIP AND AIR CONTROL ARM INSTALLATION	25
7.2.2	H336-WI DOOR ASSEMBLY	25
7.2.3	DOOR AND TRIM INSTALLATION	26
6.2.5	OPTIONAL SPARK SCREEN INSTALLATION	27
7.3	OPTIONAL NZ64 BLOWER INSTALLATION	28
7.4	NZ64 BLOWER REPLACEMENT	30
8.0	OPERATING INSTRUCTIONS	31
8.1	APPLIANCE OPERATION	31
8.2	OPERATING SOUNDS AND SMELLS	31
8.3	STARTING A FIRE	31
8.4	DRAFT CONTROL	32
8.5	STARTING THE FIRE	32
8.6	FUEL LOADING AND BURN CYCLE	34
8.7	RE-LOADING THE APPLIANCE	34
8.8	FLASH FIRES	35
8.9	OVERNIGHT BURN	35
8.10	ASH REMOVAL PROCEDURES	35
9.0	MAINTENANCE	36
9.1	RUN-AWAY OR CHIMNEY FIRE	36
9.2	FIRE EXTINGUISHERS AND SMOKE DETECTORS	36
9.3	GLASS AND GASKET REPLACEMENT	36
9.4	CREOSOTE FORMATION AND REMOVAL	37
9.5	SELECTING WOOD	38
10.0	REPLACEMENTS	39
11.0	TROUBLE SHOOTING GUIDE	41
12.0	WARRANTY	42
13.0	SERVICE HISTORY	43
14.0	NOTES	44

NOTE: Changes, other than editorial, are denoted by a vertical line in the margin.

1.0 INSTALLATION OVERVIEW

! WARNING

THIS APPLIANCE AND ITS COMPONENTS ARE DESIGNED TO BE INSTALLED AND OPERATED AS A SYSTEM. ANY ALTERATION TO OR SUBSTITUTION FOR ITEMS IN THIS SYSTEM, UNLESS ALLOWED BY THESE INSTALLATION INSTRUCTIONS, WILL VOID THE WARNOCK HERSEY LISTING AND MAY VOID THE PRODUCT WARRANTY. IT MAY ALSO CREATE A HAZARDOUS INSTALLATION. READ THROUGH THESE INSTRUCTIONS THOROUGHLY BEFORE STARTING YOUR INSTALLATION AND FOLLOW THEM CAREFULLY THROUGHOUT YOUR PROJECT.

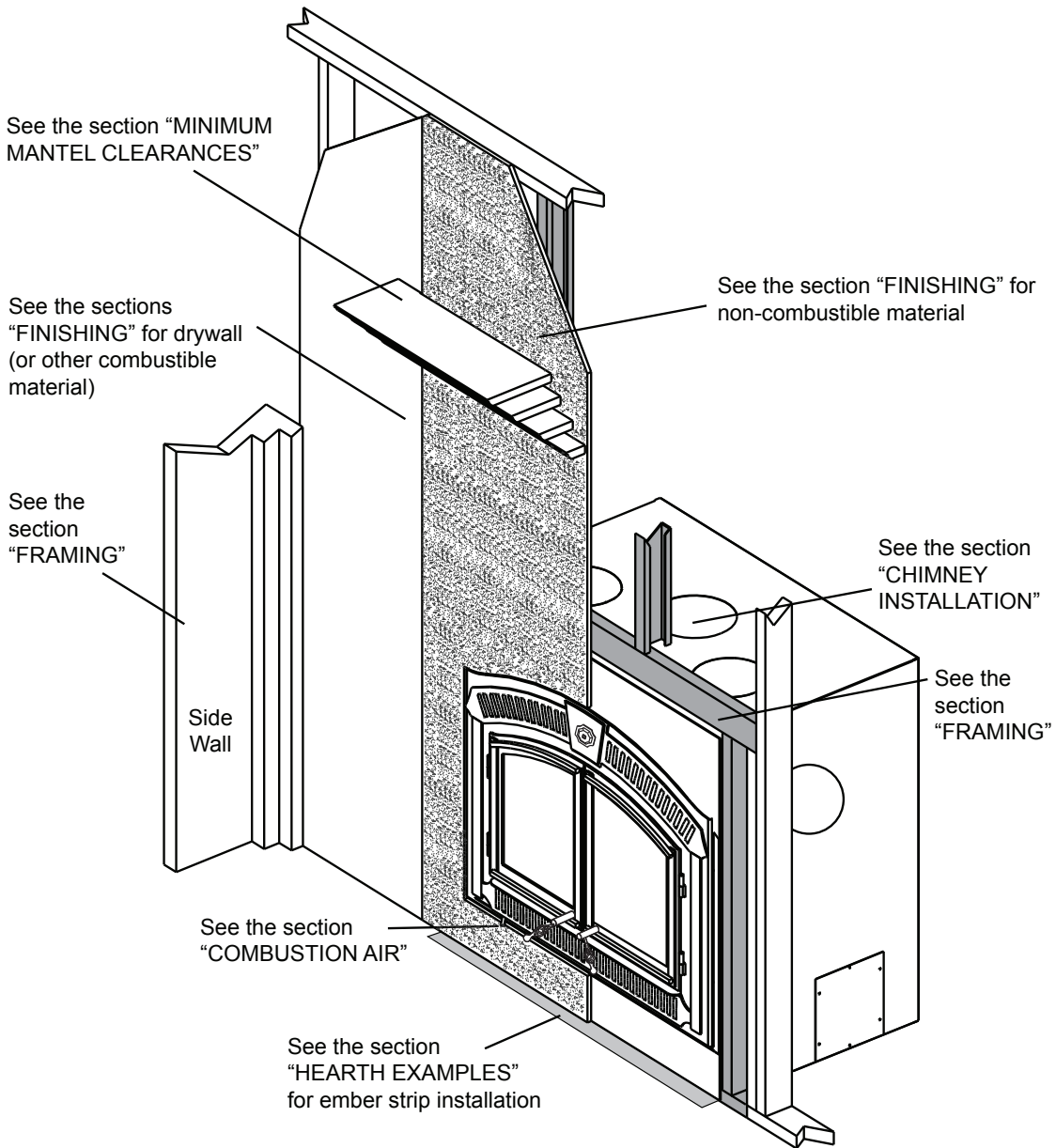

2.0 INTRODUCTION

WARNING

- **THIS APPLIANCE IS HOT WHEN OPERATED AND CAN CAUSE SEVERE BURNS IF CONTACTED.**
- Do not operate appliance before reading and understanding operating instructions. Failure to operate appliance according to operating instructions could cause fire or injury.
- Risk of burns. The appliance should be turned off and cooled before servicing.
- Do not operate without fully assembling all components.
- Do not install damaged, incomplete or substitute components.
- Risk of cuts and abrasions. Wear protective gloves and safety glasses during installation. Sheet metal edges may be sharp.
- Young children should be carefully supervised when they are in the same room as the appliance. Toddlers, young children and others may be susceptible to accidental contact burns. A physical barrier is recommended if there are at risk individuals in the house. To restrict access to an appliance or stove, install an adjustable safety gate to keep toddlers, young children and other at risk individuals out of the room and away from hot surfaces.
- Clothing or other flammable material should not be placed on or near the appliance.
- Due to high temperatures, the appliance should be located out of traffic and away from furniture and draperies.
- Ensure you have incorporated adequate safety measure to protect infants/toddlers from touching hot surfaces.
- Even after the appliance is out, the glass and/or screen will remain hot for an extended period of time.
- Check with your local hearth specialty dealer for safety screens and hearth guards to protect children from hot surfaces. These screens and guards must be fastened to the floor.
- Any safety screen or guard removed for servicing must be replaced prior to operating the appliance.
- It is imperative that the control compartments, burners and circulating blower and its passageway in the appliance and venting system are kept clean. The appliance and its venting system should be inspected before use and at least annually by a qualified service person. More frequent cleaning may be required due to excessive lint from carpeting, bedding material, etc. The appliance area must be kept clear and free from combustible materials, gasoline and other flammable vapors and liquids.
- Under no circumstances should this appliance be modified.
- Do not use this appliance if any part has been under water. Immediately call a qualified service technician to inspect the appliance and to replace any part of the control system and any gas control which has been under water.
- Do not operate the appliance with the glass door removed, cracked or broken. Replacement of the glass should be done by a licensed or qualified service person.
- Do not strike or slam shut the appliance glass door.
- Only doors / optional fronts certified with the unit are to be installed on the appliance.
- Keep the packaging material out of reach of children and dispose of the material in a safe manner. As with all plastic bags, these are not toys and should be kept away from children and infants.
- If the appliance is not properly installed, a house fire may result. Do not expose the appliance to the elements (ex. rain, etc.) and keep the appliance dry at all times. Wet insulation will produce an odour when the appliance is used.
- The chimney must be sound and free of cracks. Clean your chimney a minimum of twice a year and as required.
- The appliance is designed to burn natural wood only. Do not burn treated wood, coal, charcoal, coloured paper, cardboard, solvents or garbage. This appliance has not been tested with an unvented gas log set. To reduce risk of fire or injury, do not install an unvented gas log set into the appliance.
- Do not start a fire with chemicals or fluids such as gasoline, engine oil, etc.
- Operate only with the doors tightly closed.
- Do not let the appliance become hot enough for any part to glow red.
- Higher efficiencies and lower emissions generally result when burning air dried seasoned hardwoods, as compared to softwoods or too green or freshly cut hardwoods. Burning wet unseasoned wood can cause excessive creosote accumulation. When ignited it can cause a chimney fire that may result in a serious house fire.
- Burn wood behind the log retainer directly on the firebricks. Do not use elevated grate or otherwise raise the fire.
- Do not store the wood within appliance installation clearances or within the space required for re-fueling and ash removal.
- Your appliance requires periodic maintenance and cleaning. Failure to maintain your appliance may lead to smoke spillage in your home.

2.1 DIMENSIONS

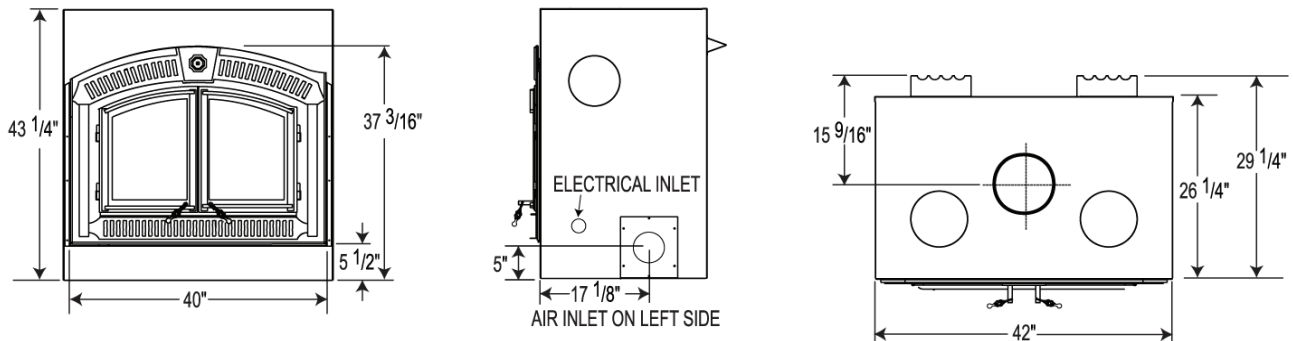

3.0 GENERAL INFORMATION

! WARNING

BEFORE INSTALLING THIS APPLIANCE, CONTACT THE LOCAL BUILDING OR FIRE AUTHORITY AND FOLLOW THEIR GUIDELINES.

THIS APPLIANCE MUST BE INSTALLED BY A QUALIFIED INSTALLER. FOLLOW THE INSTALLATION DIRECTIONS. DO NOT OPERATE WITHOUT FULLY ASSEMBLING ALL COMPONENTS.

IF THIS APPLIANCE IS NOT PROPERLY INSTALLED, A HOUSE FIRE MAY RESULT.

DO NOT EXPOSE THE APPLIANCE TO THE ELEMENTS (EX. RAIN, ETC.) AND KEEP THE APPLIANCE DRY AT ALL TIMES. WET INSULATION WILL PRODUCE AN ODOUR WHEN THE APPLIANCE IS USED.

THIS APPLIANCE IS HOT WHEN OPERATED AND CAN CAUSE SEVERE BURNS IF CONTACTED. CHILDREN AND PETS MUST BE KEPT FROM TOUCHING THE APPLIANCE WHEN IT IS HOT. CONTACT YOUR LOCAL AUTHORIZED DEALER / DISTRIBUTOR FOR SAFETY SCREENS THAT MAY BE AVAILABLE FOR THIS PRODUCT.

COMBUSTIBLE MATERIAL SUCH AS FIREWOOD, WET CLOTHING, ETC. PLACED TOO CLOSE CAN CATCH FIRE. OBJECTS PLACED IN FRONT OF THE APPLIANCE MUST BE KEPT A MINIMUM OF 48" FROM THE FRONT OF THE APPLIANCE.

ALL WIRING SHOULD BE DONE BY A QUALIFIED ELECTRICIAN AND SHALL BE IN COMPLIANCE WITH LOCAL CODES AND WITH THE NATIONAL ELECTRIC CODE ANSI/NF NO. 70-CURRENT (IN THE UNITED STATES), OR WITH THE CURRENT CSA C22.1 CANADIAN ELECTRIC CODE (IN CANADA).

Your appliance must be installed in accordance with all national and local building code standards and the standard of Chimney and Appliances, Vents and Solid Fuel Burning Appliances NFPA #211. Consult the authority having jurisdiction (such as municipal building department, fire department, fire prevention bureau, etc.) to determine the need to obtain a permit. If you are in doubt about the proper installation for your situation, contact your dealer or local building or fire official. The manufacturer does not guarantee that this appliance and its options will completely heat your entire home.



We suggest that our woodburning hearth products be installed and serviced by professionals who are certified in the U.S. by the National Fireplace Institute® (NFI) as NFI Woodburning Specialists or who are certified in Canada by Wood Energy Technical Training (WETT).



6

3.1 FEATURES

- Maximum log length of 25"
- Long burn time - up to 12 hours
- Optional 440 CFM blower for convection heat
- Thermostat for automatic control of the blower
- BTU Output per hour 10,000 to 60,000 (Cord wood method)
- Large firebox capacity - 2.78 cu. ft.
- Large doors with ceramic glass for maximum visibility
- Firebrick lining for firebox protection
- Inside or outside air for combustion

3.2 HEATING SPECIFICATIONS

! WARNING

DO NOT LET THE APPLIANCE BECOME HOT ENOUGH FOR ANY PART TO GLOW RED.

Approximate Heating Capacity up to 3,000 square feet (Will vary with the home's floor plan, insulation and outside temperature).

3.3 ELECTRICAL SPECIFICATIONS

Where applicable the blowers and motors draw < 12 amps.

3.4 PACKING LIST

Shipped with appliance:

Installation manual
Baffle
Ember Strip

Shipped with faceplate:

Installation instructions and hardware

Shipped with the door(s):

Installation instructions and hardware

3.5 CALIFORNIA PROP 65

Use of this product may produce smoke which contains chemicals known to the State of California to cause cancer, birth defects, or other reproductive harm.

3.6 EPA COMPLIANCE

This appliance has been tested in accordance with standard 40, section 60 of the Environmental Protection Agency (EPA).

3.7 RATING PLATE INFORMATION

Rating plate is located behind the appliance faceplate.

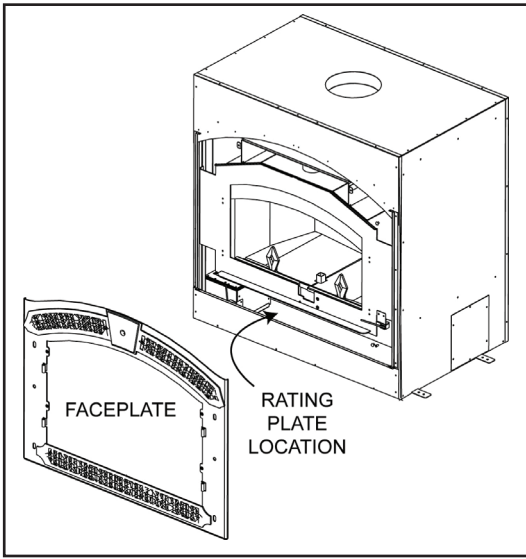

<p>LISTED FACTORY BUILT FIREPLACE FOYER PRÉFABRIQUÉ MONODIGUE CERTIFIED TO CERTIFICAT U.S.C. SRUL UL-127 FOR USE IN CANADA AND THE USA POUR UTILISATION AU CANADA ET AUX ÉTATS-UNIS</p> <p>INSTALL AND USE ONLY IN ACCORDANCE WITH THE MANUFACTURER'S INSTALLATION AND OWNER'S MANUAL. CONTACT LOCAL BUILDING OR FIRE OFFICIALS ABOUT RESTRICTIONS AND INSTALLATION INSPECTION IN YOUR AREA. DO NOT CONNECT THIS UNIT TO A CHIMNEY SERVING ANOTHER APPLIANCE.</p> <p>POUR INSTALLATION ET UTILISATION CONFORMÉMENT AU MANUEL D'INSTRUCTIONS DU FABRICANT. RENSEIGNEZ-VOUS AUPRÈS DES AUTORITÉS LOCALES DU BATIMENT OU DU SERVICE DES INCENDIES AU SUJET DES RESTRICTIONS ET DES INSPECTIONS D'INSTALLATION DANS VOTRE RÉGION. NE PAS RACCORDER À LA CHIMÉE D'UN AUTRE APPAREIL.</p> <p>MANUFACTURE DATE: DATE DE FABRICATION</p> <p>2008 2009 2010 2011 Jan/Janv. Apr/Avr. Jul/Juill. Oct/Oct. Feb/Fév. May/Mai Aug/Août. Nov/Nov. Mar/Mars Jun/Juin Sep/Sept. Dec/Déc.</p> <p>WARNING: AVERTISSEMENT</p> <p>*Never open fire door *N'ouvrez jamais la porte *Never open door while unit is hot *N'ouvrez jamais la porte quand l'appareil est encore chaud *For use with vent pipe only *À utiliser avec la tuyauterie de ventilation *Do not use in a mobile home *Ne pas utiliser dans une maison mobile</p>	<p>SERIAL NO. NZ3000 MODEL NO. NZ2000 N° DE MODÈLE NZ2000</p> <p>OPTIONAL COMPONENTS / PIÈCES OPTIONNELLES</p> <p>BLUEMENT / SOUS-PÈSE: NON ACCESSOIRES FOURNIS PAR FABRICANT/NE PAS LES UTILISER S'ILS NE SONT PAS FOURNIS PAR LE FABRICANT/NE PAS LES UTILISER S'ILS NE SONT PAS FOURNIS PAR LE FABRICANT</p> <p>MADE IN CANADA BY: FABRIQUÉ AU CANADA PAR: WOLF-STEEL BARRIE • ONTARIO • CANADA</p>	<p>COMPONENTS REQUIRED FOR INSTALLATION:</p> <p>UNIT WITH THE FOLLOWING: FACEPLATE INSTALLATION MANUAL SMITH SMITH SMITH</p> <p>CHIMNEY REQUIREMENTS (see installation manual): Chimney must be certified to one of the following standards: U.S.C. 5604, U.S.C. 5610 or U.S.C. 5620 for Canada or U.S. 1207 or UL-127 for the United States. Masonry chimney installation: Surface must meet or exceed U.S.C. 5640 M22 or U.S.C. 5610 for Canada or UL-127 for the United States.</p> <p>MINIMUM CHIMNEY HEIGHT 18 ft (5.49 m) MAXIMUM NUMBER OF ELBOWS 4 MINIMUM CHIMNEY HEIGHT 18 ft (5.49 m) FLUE COLLAR 7 1/2" MAXIMUM OFFSET ANGLE 30° OR 45° CANADA</p> <p>COMPONENTS REQUIS POUR L'INSTALLATION:</p> <p>L'UNITÉ AVEC LA SUIVANTE: FACEPLATE MANUEL D'INSTRUCTIONS D'INSTALLATION SMITH SMITH SMITH</p> <p>EXIGENCES POUR LA CHIMÉE (voir le manuel d'installations): La cheminée doit être certifiée selon l'une des normes suivantes: U.S.C. 5610 ou U.S.C. 5620 pour le Canada ou les normes U.S. 1207 ou UL-127 pour les États-Unis. Installation dans une cheminée en maçonnerie: La gaine en acier inoxydable doit être certifiée selon les normes U.S.C. 5640 M22 ou U.S.C. 5610 pour le Canada ou selon la norme UL-127 pour les États-Unis.</p> <p>HAUTEUR MINIMALE DE LA CHIMÉE 18 pi (5,49 m) NOMBRE MAXIMAL DE COUDÉS 4 HAUTEUR MINIMALE DE LA CHIMÉE 18 pi (5,49 m) RISE DÉVIAZIONE 7 1/2" ANGLE DE DÉVIAZIONE MAXIMAL 30° OU 45° CANADA</p>	<p>PREVENT CROSSBOW FIRE. INSPECT CHIMNEY AND CHIMNEY SYSTEMS, IF APPLICABLE, TWICE YEARLY AND CLEAN IF NECESSARY. DO NOT COVER OR IF COVERED OF UNIT TO COMPLY WITH ALL GOVERNING COMBUSTIBLE MATERIALS A CONSIDERABLE DISTANCE FROM APPLIANCE. PREVENT CROSSBOW FIRE. INSPECT CHIMNEY AND CHIMNEY SYSTEMS, IF APPLICABLE, TWICE YEARLY AND CLEAN IF NECESSARY. DO NOT COVER OR IF COVERED OF UNIT TO COMPLY WITH ALL GOVERNING COMBUSTIBLE MATERIALS A CONSIDERABLE DISTANCE FROM APPLIANCE. PREVENT CROSSBOW FIRE. INSPECT CHIMNEY AND CHIMNEY SYSTEMS, IF APPLICABLE, TWICE YEARLY AND CLEAN IF NECESSARY. DO NOT COVER OR IF COVERED OF UNIT TO COMPLY WITH ALL GOVERNING COMBUSTIBLE MATERIALS A CONSIDERABLE DISTANCE FROM APPLIANCE.</p> <p>PREVENT CROSSBOW FIRE. INSPECT CHIMNEY AND CHIMNEY SYSTEMS, IF APPLICABLE, TWICE YEARLY AND CLEAN IF NECESSARY. DO NOT COVER OR IF COVERED OF UNIT TO COMPLY WITH ALL GOVERNING COMBUSTIBLE MATERIALS A CONSIDERABLE DISTANCE FROM APPLIANCE.</p>																																																																
	<p>MINIMUM CLEARANCES TO COMBUSTIBLES</p> <table border="1"> <tr><td>REAR</td><td>6" (153 mm)</td><td>TO SIDING/UNIT</td></tr> <tr><td>SIDE</td><td>6" (153 mm)</td><td>FROM BASE OF UNIT</td></tr> <tr><td>FRONT</td><td>90" (2286 mm)</td><td>FROM BASE OF UNIT</td></tr> <tr><td>CHIMNEY</td><td>7" (178 mm)</td><td>TO SIDING/COMBUSTIBLES INSTALLATION INSTRUCTIONS</td></tr> <tr><td>MANTLE</td><td>1" (25 mm)</td><td>TO TOP EDGE OF MANTLE</td></tr> <tr><td>TOP FRAMING</td><td>90" (2286 mm)</td><td>FROM BASE OF UNIT</td></tr> <tr><td>SIDE FRAMING</td><td>6" (153 mm)</td><td>FROM SIDE OF UNIT</td></tr> <tr><td>ADJACENT SIDEWALL</td><td>2" (51 mm)</td><td>FROM SIDE OF FACELATE</td></tr> <tr><td>HEARTH PROTECTION</td><td>2" (51 mm)</td><td>FROM FRONT OF UNIT</td></tr> <tr><td>HEARTH PROTECTION</td><td>6" (153 mm)</td><td>FROM SIDE OF UNIT</td></tr> <tr><td>TOP OF UNIT (INCLUDES CEILING)</td><td>84" (2133 mm)</td><td>FROM BASE OF UNIT</td></tr> </table> <p>*FOR FURTHER INFORMATION SEE THE MANUFACTURER'S INSTALLATION AND OPERATING MANUAL.</p> <p>DO NOT REMOVE THIS LABEL</p>	REAR	6" (153 mm)	TO SIDING/UNIT	SIDE	6" (153 mm)	FROM BASE OF UNIT	FRONT	90" (2286 mm)	FROM BASE OF UNIT	CHIMNEY	7" (178 mm)	TO SIDING/COMBUSTIBLES INSTALLATION INSTRUCTIONS	MANTLE	1" (25 mm)	TO TOP EDGE OF MANTLE	TOP FRAMING	90" (2286 mm)	FROM BASE OF UNIT	SIDE FRAMING	6" (153 mm)	FROM SIDE OF UNIT	ADJACENT SIDEWALL	2" (51 mm)	FROM SIDE OF FACELATE	HEARTH PROTECTION	2" (51 mm)	FROM FRONT OF UNIT	HEARTH PROTECTION	6" (153 mm)	FROM SIDE OF UNIT	TOP OF UNIT (INCLUDES CEILING)	84" (2133 mm)	FROM BASE OF UNIT	<p>CET APPAREIL DE CHAUFFAGE A ÉTÉ TESTÉ EN CONFORMITÉ AVEC LA NORME 40, SECTION 60 DE L'ÉNERGIE (ÉPA) POUR LA PROTECTION DE L'ENVIRONNEMENT.</p> <p>DÉGAGEMENTS MINIMAUX DE LA CHIMÉE PRÉFABRIQUÉE STANDARD AUX MATÉRIELS COMBUSTIBLES</p> <table border="1"> <tr><td>ARRIÈRE</td><td>6" (153 mm)</td><td>DES CÔTÉS DE L'UNITÉ</td></tr> <tr><td>CÔTÉ</td><td>6" (153 mm)</td><td>DU CÔTÉ DE L'UNITÉ</td></tr> <tr><td>FRONT</td><td>90" (2286 mm)</td><td>DE LA BASE DE L'UNITÉ</td></tr> <tr><td>CHIMÉE</td><td>7" (178 mm)</td><td>VERS LES MATÉRIELS COMBUSTIBLES D'INSTALLATION DU FABRICANT</td></tr> <tr><td>TABLETTE</td><td>1" (25 mm)</td><td>DU NIVEAU DE LA TABLETTE</td></tr> <tr><td>DESUS</td><td>90" (2286 mm)</td><td>DE LA BASE DE L'UNITÉ</td></tr> <tr><td>CÔTÉ</td><td>6" (153 mm)</td><td>DU CÔTÉ DE L'UNITÉ</td></tr> <tr><td>MUR ADJACENT</td><td>2" (51 mm)</td><td>DU BORD DE LA PAROISSE</td></tr> <tr><td>PROTECTION DE PLANCHER</td><td>2" (51 mm)</td><td>DEVANT L'UNITÉ</td></tr> <tr><td>PROTECTION DE PLANCHER</td><td>6" (153 mm)</td><td>DES CÔTÉS DE L'UNITÉ</td></tr> <tr><td>*HAUT DE L'APPAREIL (PLAFOND DE L'ENLÈVÉ)</td><td>84" (2133 mm)</td><td>DE LA BASE DE L'UNITÉ</td></tr> </table> <p>*POUR PLUS D'INFORMATIONS, CONSULTEZ LE MANUEL D'INSTRUCTIONS DU FABRICANT.</p> <p>NE RETIREZ PAS CETTE PLAQUE</p>	ARRIÈRE	6" (153 mm)	DES CÔTÉS DE L'UNITÉ	CÔTÉ	6" (153 mm)	DU CÔTÉ DE L'UNITÉ	FRONT	90" (2286 mm)	DE LA BASE DE L'UNITÉ	CHIMÉE	7" (178 mm)	VERS LES MATÉRIELS COMBUSTIBLES D'INSTALLATION DU FABRICANT	TABLETTE	1" (25 mm)	DU NIVEAU DE LA TABLETTE	DESUS	90" (2286 mm)	DE LA BASE DE L'UNITÉ	CÔTÉ	6" (153 mm)	DU CÔTÉ DE L'UNITÉ	MUR ADJACENT	2" (51 mm)	DU BORD DE LA PAROISSE	PROTECTION DE PLANCHER	2" (51 mm)	DEVANT L'UNITÉ	PROTECTION DE PLANCHER	6" (153 mm)	DES CÔTÉS DE L'UNITÉ	*HAUT DE L'APPAREIL (PLAFOND DE L'ENLÈVÉ)	84" (2133 mm)
REAR	6" (153 mm)	TO SIDING/UNIT																																																																	
SIDE	6" (153 mm)	FROM BASE OF UNIT																																																																	
FRONT	90" (2286 mm)	FROM BASE OF UNIT																																																																	
CHIMNEY	7" (178 mm)	TO SIDING/COMBUSTIBLES INSTALLATION INSTRUCTIONS																																																																	
MANTLE	1" (25 mm)	TO TOP EDGE OF MANTLE																																																																	
TOP FRAMING	90" (2286 mm)	FROM BASE OF UNIT																																																																	
SIDE FRAMING	6" (153 mm)	FROM SIDE OF UNIT																																																																	
ADJACENT SIDEWALL	2" (51 mm)	FROM SIDE OF FACELATE																																																																	
HEARTH PROTECTION	2" (51 mm)	FROM FRONT OF UNIT																																																																	
HEARTH PROTECTION	6" (153 mm)	FROM SIDE OF UNIT																																																																	
TOP OF UNIT (INCLUDES CEILING)	84" (2133 mm)	FROM BASE OF UNIT																																																																	
ARRIÈRE	6" (153 mm)	DES CÔTÉS DE L'UNITÉ																																																																	
CÔTÉ	6" (153 mm)	DU CÔTÉ DE L'UNITÉ																																																																	
FRONT	90" (2286 mm)	DE LA BASE DE L'UNITÉ																																																																	
CHIMÉE	7" (178 mm)	VERS LES MATÉRIELS COMBUSTIBLES D'INSTALLATION DU FABRICANT																																																																	
TABLETTE	1" (25 mm)	DU NIVEAU DE LA TABLETTE																																																																	
DESUS	90" (2286 mm)	DE LA BASE DE L'UNITÉ																																																																	
CÔTÉ	6" (153 mm)	DU CÔTÉ DE L'UNITÉ																																																																	
MUR ADJACENT	2" (51 mm)	DU BORD DE LA PAROISSE																																																																	
PROTECTION DE PLANCHER	2" (51 mm)	DEVANT L'UNITÉ																																																																	
PROTECTION DE PLANCHER	6" (153 mm)	DES CÔTÉS DE L'UNITÉ																																																																	
*HAUT DE L'APPAREIL (PLAFOND DE L'ENLÈVÉ)	84" (2133 mm)	DE LA BASE DE L'UNITÉ																																																																	

3.8 CARE OF GLASS

If the glass is not kept clean permanent discoloration and / or blemishes may result. Normally a hot fire will clean the glass. The most common reasons for dirty glass include: not using sufficient fuel to get the appliance thoroughly hot, using green or wet wood, closing the draft so far that there is insufficient air for complete combustion. If it is necessary to clean the glass, buff lightly with a clean dry cloth and non-abrasive cleaner.

DO NOT CLEAN GLASS WHEN HOT! Clean the glass after the first 10 hours of operation with a recommended appliance glass cleaner. Thereafter clean as required.

The glass is very strong but do not let burning fuel rest or fall against it and always close the door gently. **NEVER FORCE IT SHUT!**

If the glass should ever crack or break while the fire is burning, do not open the door until the fire is out and do not operate the appliance again until the glass has been replaced, available from your Authorized dealer. **DO NOT SUBSTITUTE MATERIALS.**

! WARNING



HOT GLASS WILL CAUSE BURNS.

DO NOT TOUCH GLASS UNTIL COOLED.

NEVER ALLOW CHILDREN TO TOUCH GLASS.

3.9 HI-EFFICIENCY HEATING

To operate this hi-efficiency appliance as a basic system, the blower is not required, however, to enhance its efficiency a blower is recommended.

3.9.1 HOT AIR GRAVITY VENT SYSTEM (NZ220)

! WARNING

ALL HOT AIR GRAVITY VENTS MUST BE INSULATED.

May be used to distribute heat to an adjoining room (located either above, or beside the room containing the appliance) by way of vents, eliminating the need of an additional blower. While this system may be used in conjunction with the optional blowers, it could reduce the flow of hot air being distributed to additional rooms. It must be experimented with and the dampers adjusted manually to suit your requirements. This may take a few attempts; thereafter adjustments should no longer be required as is normally experienced with your central heating system registers. No more than **two** hot air gravity vents can be installed to appliance. Individual vent runs are not to exceed 10 feet.

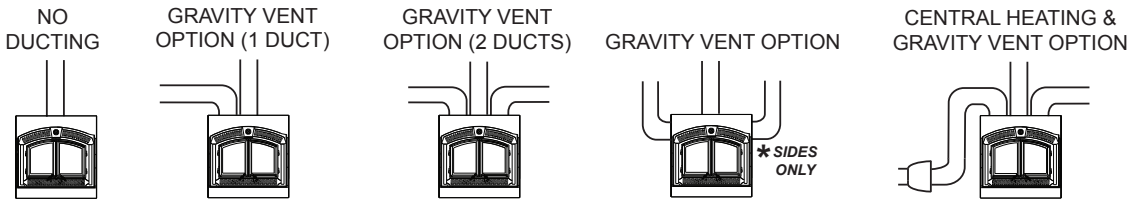
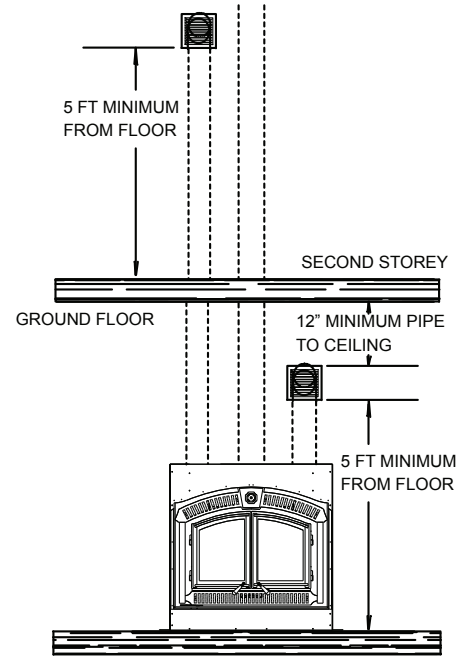
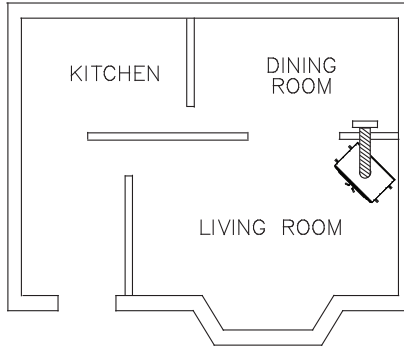

* When installed with a masonry chimney, the hot air gravity and central heating system can only be installed off the sides.

3.9.2 CENTRAL HEATING SYSTEM (NZ62CH)

May be used to heat rooms up to 50 feet from the appliance. A wall mounted thermostat located in the room to be heated controls the blower supplying warm air from the room containing the appliance. Consult with a heating specialist to ensure a proper duct layout for your home. If the NZ62CH is installed at the bottom of the appliance, it could introduce a cool draft into the room that the appliance is installed in. When attached to the top or sides of the appliance, it provides a higher heat output. This option may not be used in mobile homes.

EXAMPLE OF DEDICATED DUCTING SYSTEM

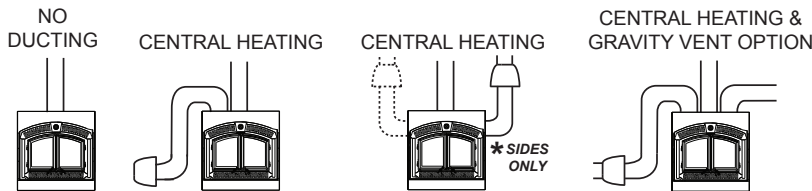
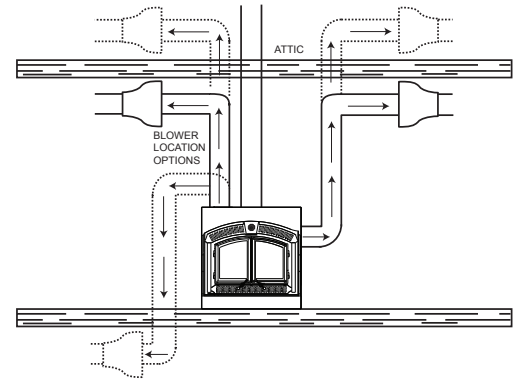
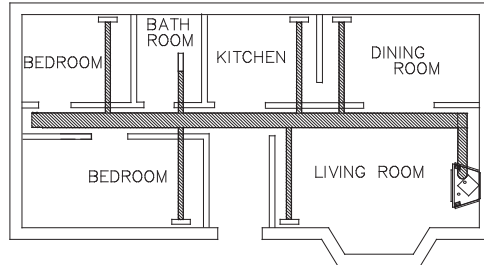

* When installed with a masonry chimney, the hot air gravity and central heating system can only be installed off the sides.

3.9.3 BLOWER CIRCULATION (NZ64)

The NZ64 provides an ideal means of circulating warm air within the room it resides. The blower will only operate when the doors are fully closed. We recommend installing the blower in a different room or even a different level of the house. This will generate greater air movement and improve the distribution of the warm air coming from the appliance as well as improving air movement in the summer months if using the summer by pass switch option. These options may be incorporated with one another. If the optional blower is to be installed, make provision during framing to route a 110 volt power line to the appliance. Detailed installation instructions are included with each venting kit.

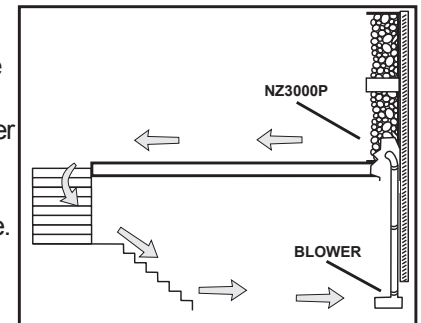

4.0 INSTALLATION PLANNING

! WARNING

WEAR GLOVES AND SAFETY GLASSES FOR PROTECTION.

CAREFULLY FOLLOW THE INSTRUCTIONS FOR ASSEMBLY OF THE PIPE AND OTHER PARTS NEEDED TO INSTALL THE APPLIANCE. FAILURE TO DO SO MAY RESULT IN A FIRE, ESPECIALLY IF COMBUSTIBLES ARE TOO CLOSE TO THE APPLIANCE OR CHIMNEY AND AIR SPACES ARE BLOCKED, PREVENTING THE FREE MOVEMENT OF COOLING AIR.

DO NOT DRAW OUTSIDE AIR FROM GARAGE SPACES. EXHAUST PRODUCTS OF GASOLINE ENGINES ARE HAZARDOUS.

DO NOT INSTALL OUTSIDE AIR DUCTS SUCH THAT THE AIR MAY BE DRAWN FROM ATTIC SPACES, BASEMENTS OR ABOVE THE ROOFING WHERE OTHER HEATING APPLIANCES OR FANS AND CHIMNEYS EXHAUST OR UTILIZE AIR. THESE PRECAUTIONS WILL REDUCE THE POSSIBILITY OF APPLIANCE SMOKING OR AIR FLOW REVERSAL.

THE OUTSIDE AIR INLET MUST REMAIN CLEAR OF LEAVES, DEBRIS ICE AND/OR SNOW. IT MUST BE UNRESTRICTED WHILE APPLIANCE IS IN USE TO PREVENT ROOM AIR STARVATION WHICH CAN CAUSE SMOKE SPILLAGE AND AN INABILITY TO MAINTAIN A FIRE. SMOKE SPILLAGE CAN ALSO SET OFF SMOKE ALARMS.

NEGATIVE PRESSURE WITHIN YOUR HOME MAY INADVERTENTLY AFFECT YOUR APPLIANCE.

TO PREVENT CONTACT WITH SAGGING OR LOOSE INSULATION, THE APPLIANCE MUST NOT BE INSTALLED AGAINST VAPOUR BARRIERS OR EXPOSED INSULATION. LOCALIZED OVERHEATING COULD OCCUR AND A FIRE COULD RESULT.

DO NOT USE MAKESHIFT COMPROMISES DURING INSTALLATION. DO NOT BLOCK OR RESTRICT AIR, GRILLE OR LOUVRE OPENINGS. DO NOT ADD A HOOD.

68.3

4.1 LOCATION AND CLEARANCES

! WARNING

DO NOT INSTALL INTO ANY AREA HAVING A HEIGHT LESS THAN 7 FEET (CEILING OF ENCLOSURE TO APPLIANCE BOTTOM, EXCLUDING HEARTH HEIGHT).

IMPORTANT

This appliance, fully dressed, weighs 575 lbs. Ensure there is adequate floor support for the appliance, chimney and finishing material. Some material could weigh thousands of pounds.

We recommend that the appliance be secured to the floor in all cases.

Remove and discard the lifting handles. Bend the tabs down and secure the appliance to the floor.

The location of windows, doors and the traffic flow in the room where the appliance is to be located should be considered. If possible, you should choose a location where the chimney will pass through the house without cutting a floor or roof joist.

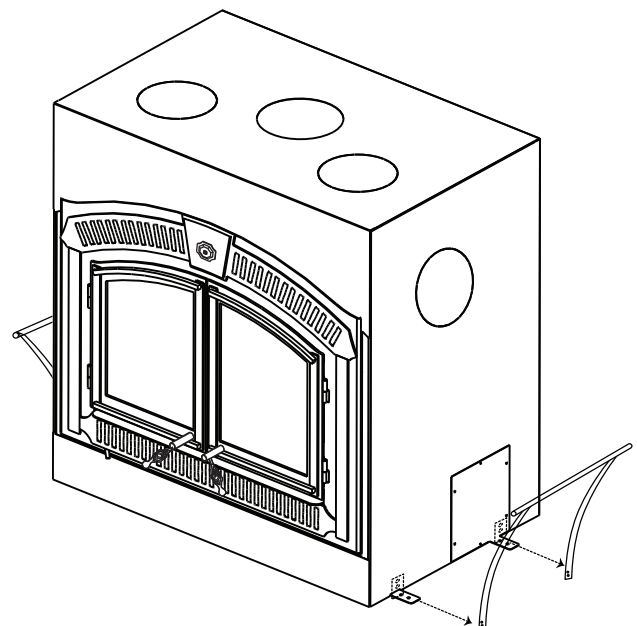

4.2 COMBUSTION AIR

Model NZ3000 has the option of taking outside air directly into the appliance through the opening on the left hand side or taking inside air through the lower front grille or a combination of both. **For inside air push in the control slider.**

If the optional outside air kit (available through your authorized dealer) is installed, it must not draw air from the attic or garage. **For outside air pull out the air control slider.** It may only come from outside the house. The maximum length of the 4" air duct is 20 feet; for greater lengths enlarge the duct to a 6" diameter.

Decide on the most convenient location for the outside air inlet duct and hood which may be installed above or below floor level but must be installed above grade level.

Make a 5" hole in an outside wall of the house. From outside, place the outside air hood into the hole, open side down.

At each end, carefully pull back the insulation sleeve exposing the flexible duct. Apply sealant to both the outside air hood collar and the connector collar at the appliance. Place the insulated flexible duct over the outside air hood and over the appliance outside air connector. Carefully push the insulation sleeve back over the duct. Using the clamps, fasten the insulated duct into place on both sides.

Cold air flow can be minimized by putting a dip or loop in the duct creating a cold air trap. This trap can also help prevent heat build-up and exhausting out the intake due to stack effect. The outside air kit inlet should be positioned in a manner that will not allow snow, leaves, etc. to block the inlet. In some installations the air duct may need to be run vertically.

NOTE: Appliance must be set for inside air if outside air is not connected.

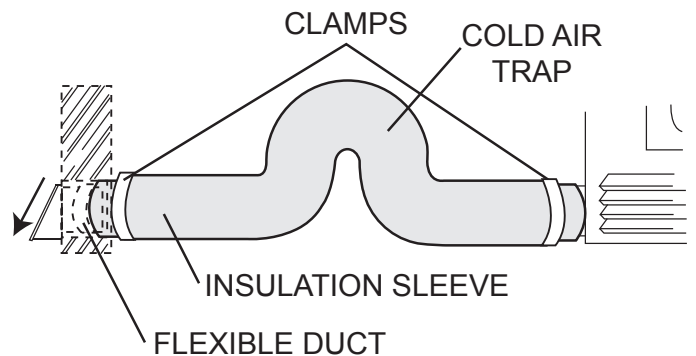
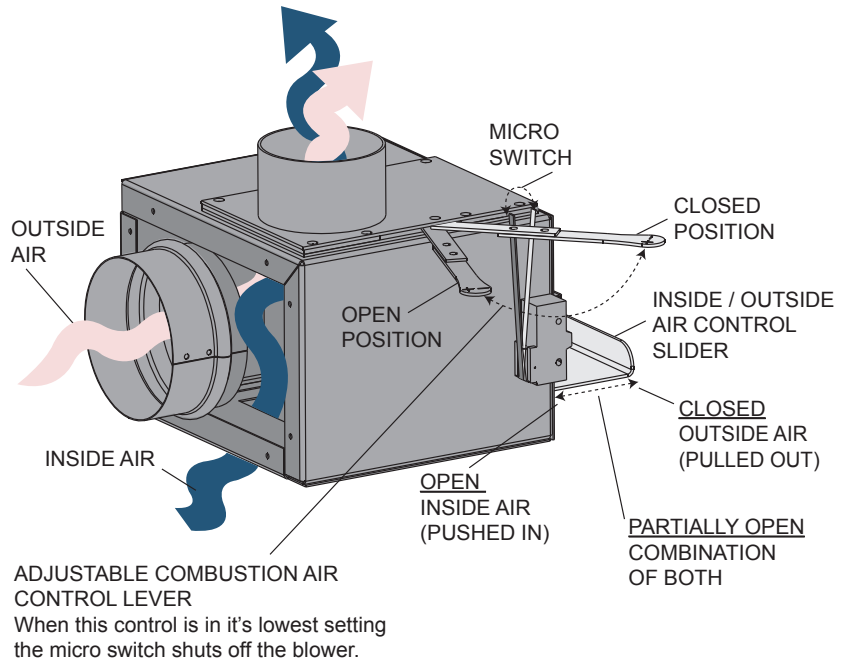
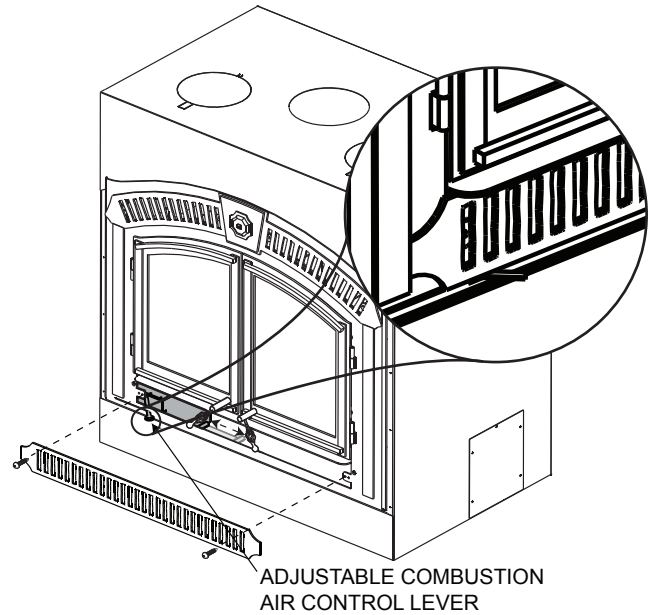

4.3 EMBER STRIP AND HEARTH EXTENSIONS

! WARNING

HEARTH EXTENSIONS ARE TO BE INSTALLED ONLY AS DESCRIBED TO PREVENT HIGH TEMPERATURES FROM OCCURRING ON CONCEALED COMBUSTIBLE MATERIALS. HEARTH EMBER STRIPS PREVENT BURNING OR HOT PARTICLES FROM INADVERTENTLY FALLING DIRECTLY ON COMBUSTIBLE SURFACES IN THE EVENT THE BUILDING SHOULD SETTLE AND DISTURB THE ORIGINAL CONSTRUCTION.

An acceptable 54" x 20" non-combustible (i.e. brick, stone or ceramic tile) hearth extension must be installed.

The hearth must extend a minimum 20" in front of the appliance although if raised a minimum of 6 1/2" the 20" may be reduced to a minimum of 18".

The hearth must extend a minimum of 6" to both sides of the appliance (54").

The hearth must be a minimum of 1" thick cement board (or equivalent) plus 1/4" ceramic tile.

Ensure that the gap between the appliance and a non-combustible hearth extension is sealed with sand/cement grout or covered with an ember strip (or both) to prevent sparks and embers from falling into this area.

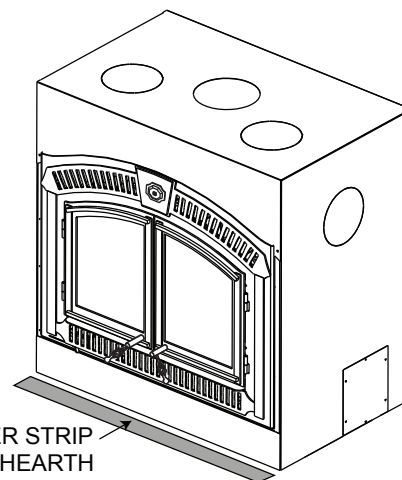

EMBER STRIP
(See "HEARTH
EXAMPLES" Section)

Raised hearths must be constructed of non-combustible materials such as cement blocks or bricks.

While the appliance can be installed directly on the floor, a non-combustible hearth extension is required in front of the appliance, that must not be built higher than the bottom of the appliance faceplate. It may therefore be advisable to build the appliance on a raised platform.

A raised hearth together with the appliance built on a raised platform is recommended for easier wood loading and fire viewing.

4.4 HEARTH EXAMPLES

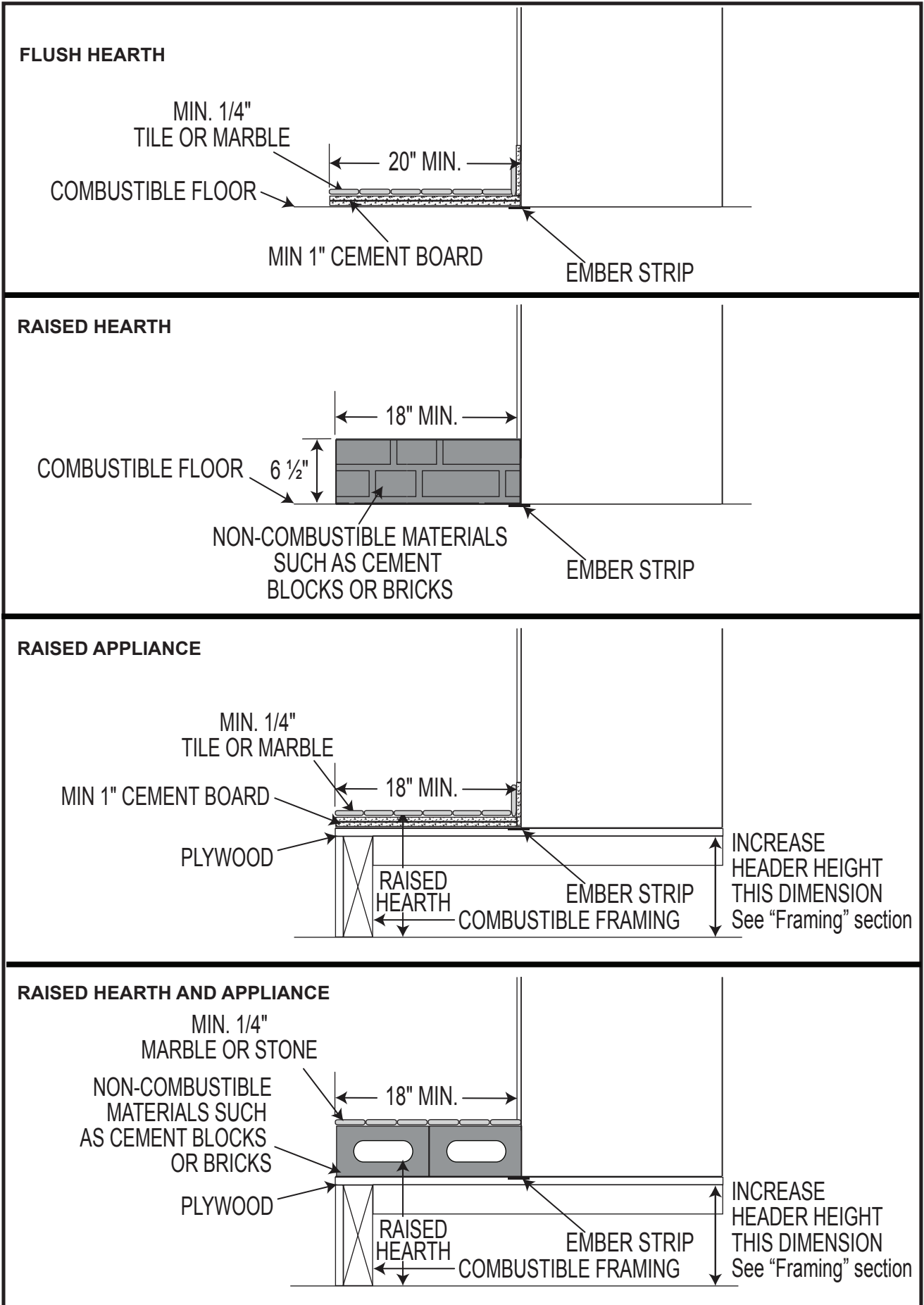

4.5 MINIMUM CLEARANCE TO COMBUSTIBLES

MAINTAIN THESE MINIMUM CLEARANCES TO COMBUSTIBLES:	
Framed Enclosure:	
Rear	- 0" to stand-offs
Sides	- 6"
Ceiling (Enclosure)	- 84" from the base of the appliance
Ceiling (Room)	- 84" from the base of the appliance
Chimney	- 2"
Hot Air Gravity Ductwork Insulation	- 1"

Objects placed in front of the appliance must be kept a minimum of 48" away from the front of the appliance.

4.6 MINIMUM CLEARANCES TO COMBUSTIBLE ENCLOSURES

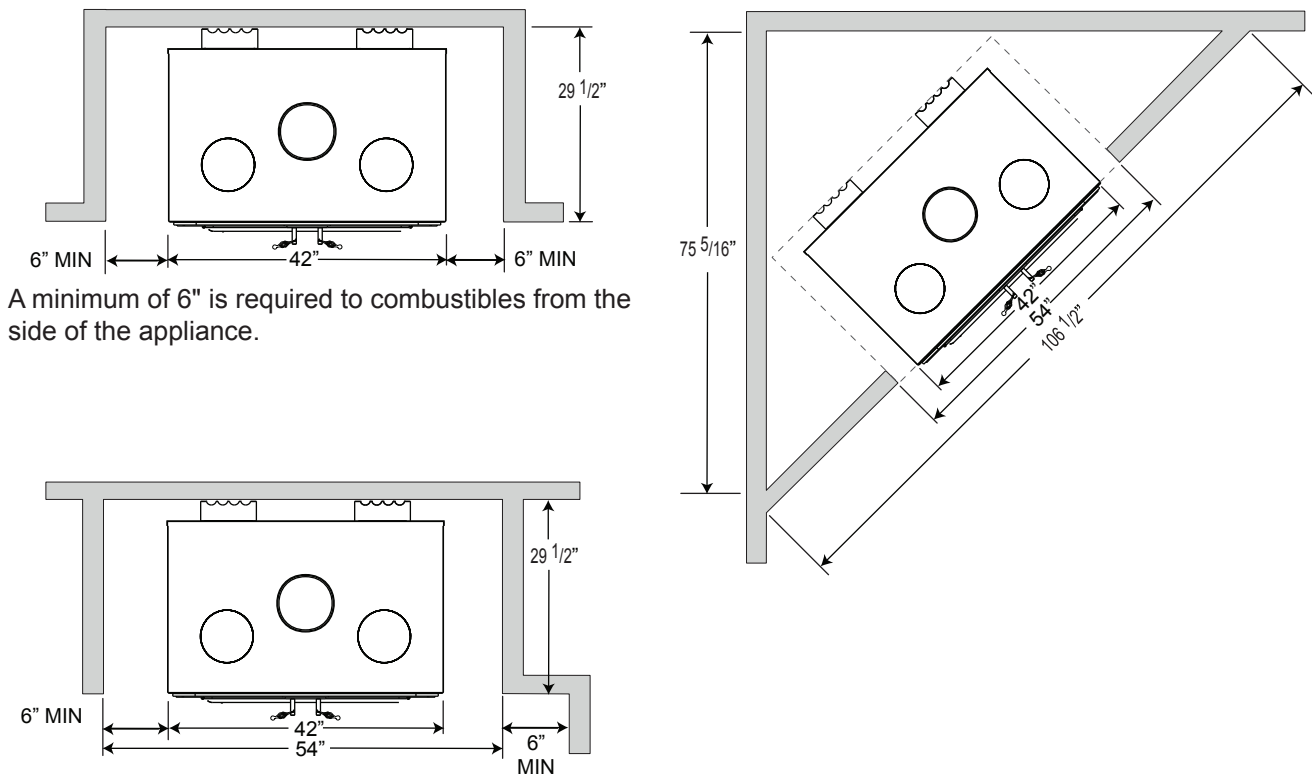

NOTE: When constructing the enclosure allow for finishing material thickness to maintain clearances.

5.0 CHIMNEY INSTALLATION

! WARNING

NEVER INSTALL A SINGLE WALL SLIP SECTION OR SMOKE PIPE IN A CHASE STRUCTURE. THE HIGHER TEMPERATURE OF THIS SINGLE WALL PIPE MAY RADIATE SUFFICIENT HEAT TO COMBUSTIBLE CHASE MATERIALS TO CAUSE A FIRE.

TO AVOID DANGER OF FIRE, ALL INSTRUCTIONS MUST BE STRICTLY FOLLOWED, INCLUDING THE PROVISION OF AIR SPACE CLEARANCE BETWEEN CHIMNEY SYSTEM AND ENCLOSURE. TO PROTECT AGAINST THE EFFECTS OF CORROSION ON THOSE PARTS EXPOSED TO THE WEATHER, WE RECOMMEND THAT THE CHASE TOP BE PAINTED WITH A RUST-RESISTANT PAINT.

MAINTAIN A MINIMUM 2" AIR CLEARANCE TO ALL PARTS OF THE CHIMNEY SYSTEM AT ALL TIMES. FAILURE TO MAINTAIN THIS 2" AIR CLEARANCE WILL CAUSE A STRUCTURE FIRE.

DETAILED INSTRUCTIONS FOR INSTALLATION OF THE CHASE TOP, STORM COLLAR AND TERMINATION CAP ARE PACKAGED WITH THESE PARTS.

FIRESTOP SPACERS MUST BE USED WHENEVER THE CHIMNEY PENETRATES A CEILING/FLOOR AREA.

THE CHIMNEY MUST BE SOUND AND FREE OF CRACKS. CLEAN YOUR CHIMNEY A MINIMUM OF TWICE A YEAR AND AS REQUIRED.

NOTE: All venting connections must be in compliance with the chimney manufacturers installation instructions.

This appliance was tested to CAN/ULC S610 and UL 127 Factory Built Fireplace Standards. This appliance has met the test criteria for Zero Clearance Installation to Combustible Surfaces and Certified to burn firewood only.

Any 7" or 8" diameter chimney listed to these standards may be installed. In accordance with these standards, the appliance may also be connected to any chimney listed to CAN/ULC-S604 and CAN/ULC-S629 for Canada or UL-103HT for the United States.

Installation of all types of factory-built chimney systems is to be in accordance with the chimney manufacturers installation instructions. An appropriate chimney manufacturers anchor base plate is required in order to initiate their system. An anchor base plate gasket is supplied that suits a 7" chimney. If 8" is used then cut hole in gasket to suit. Use the high temperature gasket, supplied, to seal between the anchor plate and the appliance top.



ANCHOR PLATE FOR A FACTORY BUILT CHIMNEY

Complete installation instructions for Selkirk Ultra Temp Chimney for Canada and Ultra Temp Platinum Chimney for USA, refer to: www.selkirkinc.com/products/chimney.aspx

A chimney venting the appliance shall not vent any other appliance. The minimum overall chimney height from the top of the appliance is 15 feet. The maximum overall chimney height from the top of the appliance is 34 feet.

Factory-built chimney systems for use in dwellings constructed for three or more families must be enclosed above the room in which the appliance is located. This enclosure must have a fire resistance rating equal to or greater than that of the floor or roof assembly through which they pass.

The chimney should not be built with an offset angle in excess of 45° in Canada and 30° in USA.

Ensure that minimum clearances are maintained.

Portions of the chimney that extend through accessible spaces must always be encased to avoid personal contact with the chimney and thereby avoid damage to the chimney.

The chimney must be supported at a maximum of 20 foot intervals (approx. 200 lbs/20 FT).

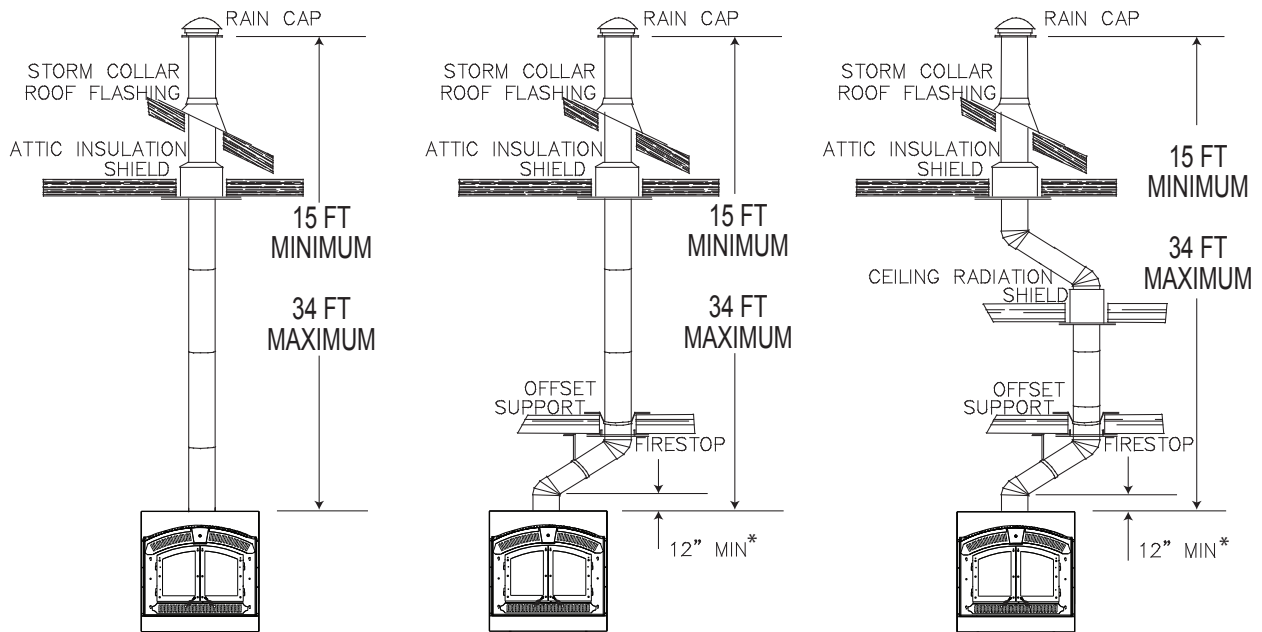

* The first flue offset closest to the top of the fireplace must be a minimum distance of 12" from the top of the fireplace.

1. Move the fireplace into position. Try to center the exhaust flue of the fireplace, midpoint between two joists to prevent having to cut them. Use a plumb bob to line up the centre.
2. Cut and frame an opening in the ceiling to provide a minimum clearance of 2" between the outside of the chimney and any combustible material. **DO NOT FILL THIS SPACE WITH ANY TYPE OF MATERIAL!** Nail headers between the joists for extra support. Firestop spacers must be placed on each framed opening in any floor or ceiling that the chimney passes through.

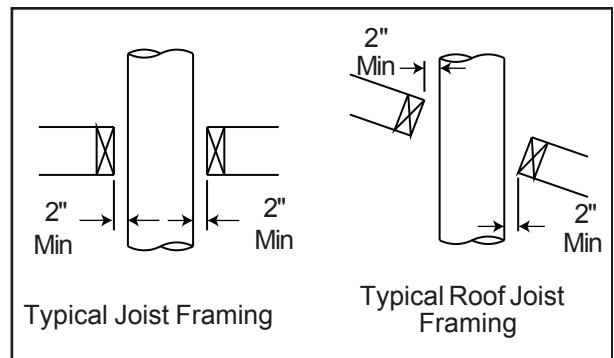

3. Hold a plumb bob from the underside of the roof to determine where the opening in the roof should be. Cut and frame the roof opening maintaining proper 2" clearances.

NOTE: 30° or 45° offsets may be installed back to back.

5.1 ADDING CHIMNEY SECTIONS

Add chimney sections, securely, to the required height. If the chimney system is enclosed within the attic area, a rafter radiation shield is required.

The chimney must extend at least 3 feet above its point of contact with the roof and at least 2 feet higher than any wall, roof or building within 10 feet.

If the chimney extends more than 5 feet above the roof, it must be secured using a roof brace or guide wires.

A raincap must be installed to avoid internal damage and corrosion.

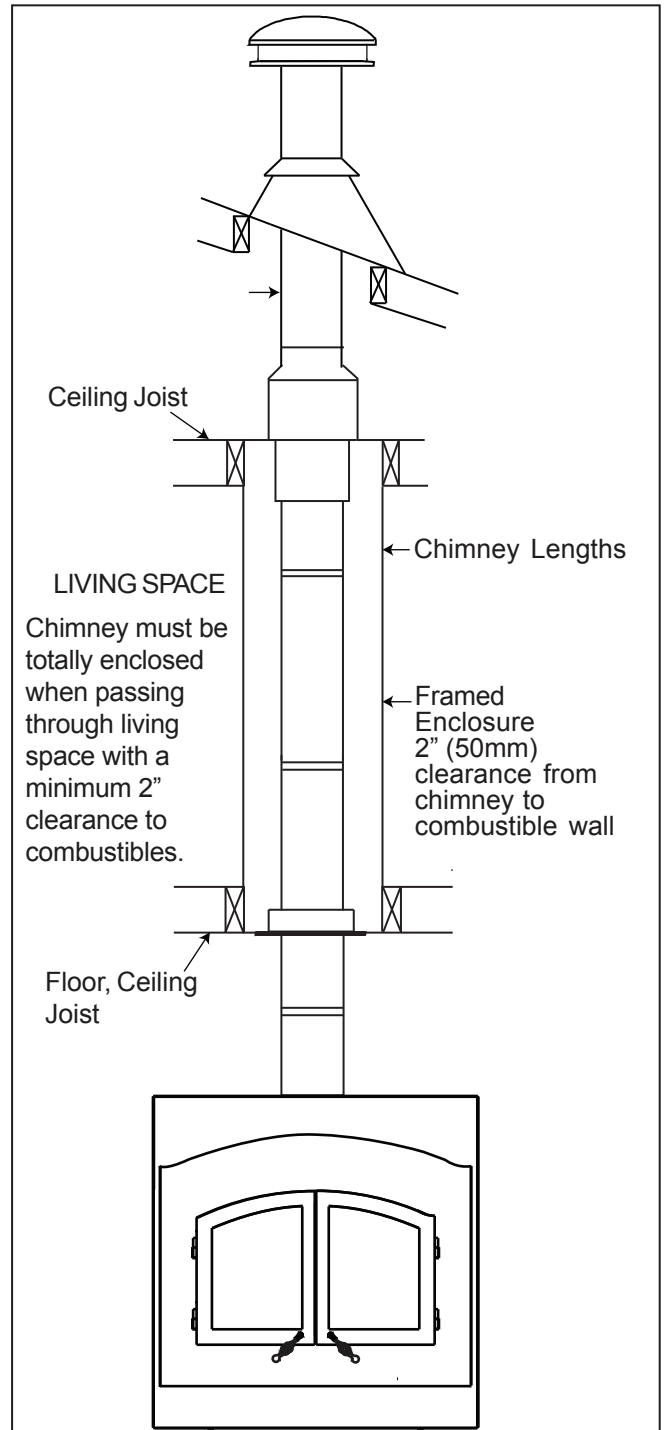
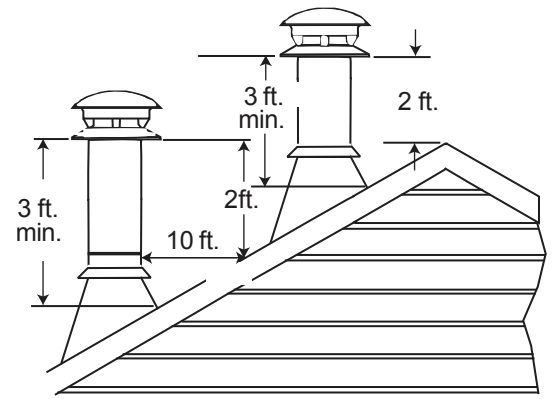

5.2 OFFSET CHIMNEY INSTALLATION

! WARNING

CHIMNEY SECTIONS INSTALLED BETWEEN AN OFFSET AND RETURN REQUIRE STRUCTURAL SUPPORT TO REDUCE OFF-CENTER LOADING AND TO PREVENT CHIMNEY SECTIONS FROM SEPARATING AT THE CHIMNEY JOISTS.

THE CHIMNEY SHOULD NOT BE BUILT WITH AN OFFSET ANGLE IN EXCESS OF 45° IN CANADA AND 30° IN USA. DO NOT COMBINE OFFSET CHIMNEY COMPONENTS TO EXCEED THESE ANGLES.

The first flue offset closest to the top of the unit must be a minimum distance of 12" from the top of the appliance.

Attach an elbow to the chimney section, angled toward the offset. Secure with 3 sheet metal screws. To achieve the minimum offset, attach and secure a second elbow. To achieve longer offsets, you may install any available length of chimney pipe between the elbows to a maximum length of 4'. Supports must be used on the first vertical chimney section after a return elbow.

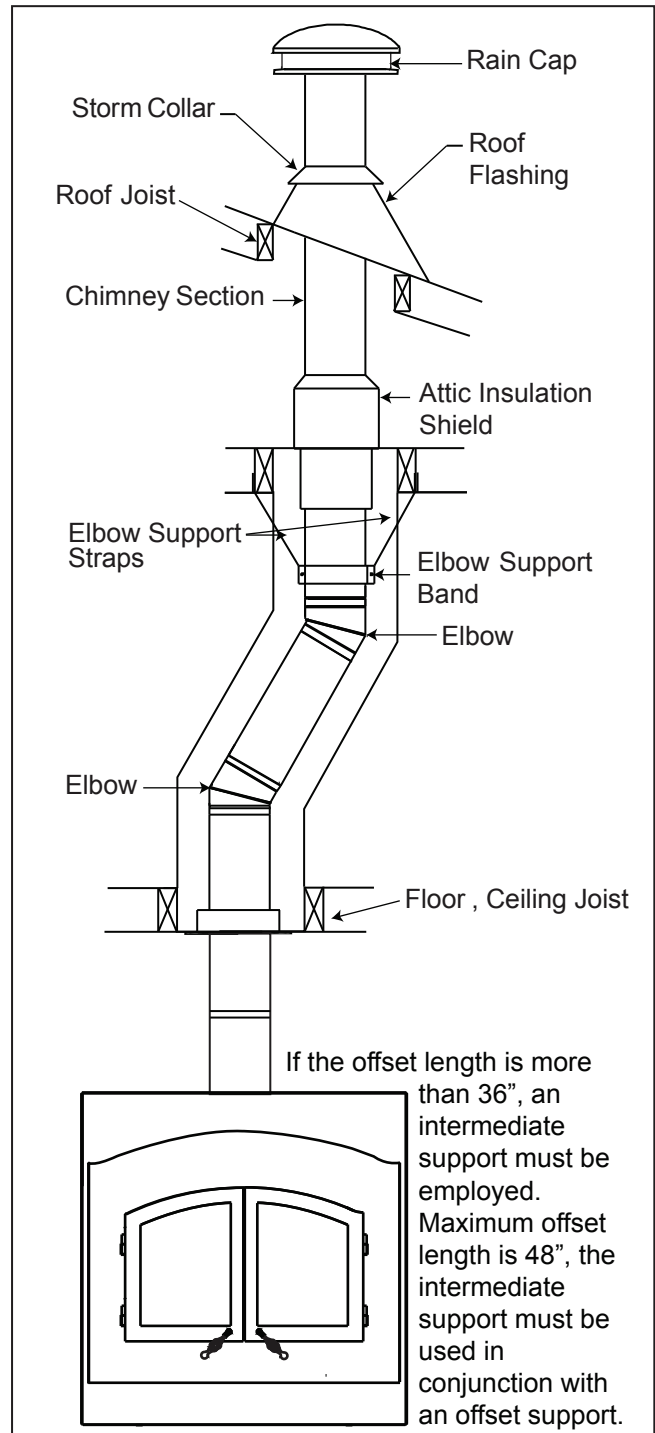

5.3 INSTALLING FLASHING AND STORM COLLAR

Remove the nails from the shingles above and to the sides of the chimney. Place the flashing over the chimney pipe and slide underneath the sides and upper edge of the shingles. Ensure that the chimney pipe is properly centered within the flashing, giving a 3/4" margin all around. Fasten to the roof on the top and sides. **DO NOT NAIL** through the lower portion of the flashing. Make weather-tight by sealing with caulking. Where possible, cover the sides and top edges of the flashing with roofing material. Apply waterproof caulking, provided with the flashing, around the chimney, 1" above the top of the flashing and push the storm collar down into the caulking. Insert a rain cap onto the top of the last chimney section.

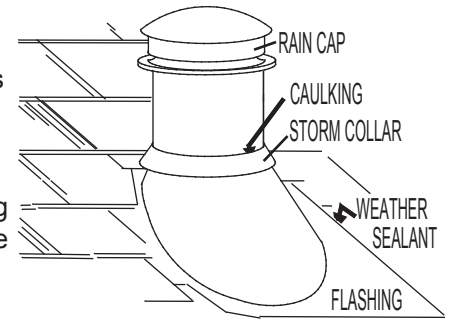

5.4 CONNECTION TO A MASONRY CHIMNEY

The fireplace may be connected to either a lined or unlined masonry chimney.

If the chimney is lined, the flues must be made of vitrified clay and be in sizes of 8" square or 8" round (inside diameters) or 8"x12" with a minimum height of 15 feet above the fireplace. Eight inch round flues are recommended. Installation must conform to both national and local code requirements.

If the chimney is unlined, a stainless steel liner listed to either Standard ULC-S640M in Canada or UL-1777 in the USA, must be used: Liners for New Masonry Chimneys, may be used to connect the fireplace to the chimney. The liner must be continuous from the fireplace to the chimney cap and be installed only per manufacturers instructions. In both cases, the chimney structure must be supported by angle iron anchored into the masonry walls. The allowable masonry used in chimney construction is 3-1/2" brick, solidly mortared and must fully encase the flue. Ensure there are no leaks.

In no case is the masonry enclosure to be supported by the fireplace. Allow a 1" (one inch) air cavity for expansion.

NOTE: The flue tile support is to be suspended on appropriate lintels.

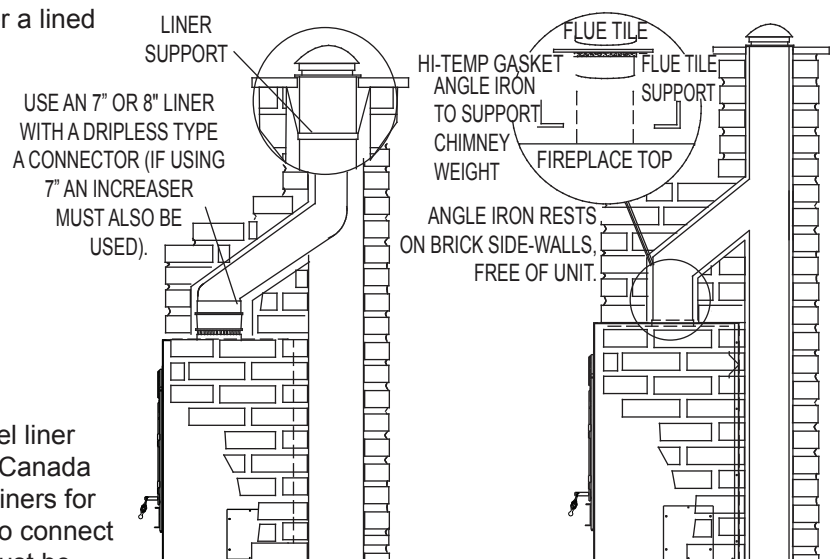

FOR A MASONRY FIREPLACE USE A FLUE TILE SUPPORT.

6.0 APPLIANCE INSTALLATION

6.1 FRAMING

! WARNING

IN ORDER TO AVOID THE POSSIBILITY OF EXPOSED INSULATION OR VAPOUR BARRIER COMING IN CONTACT WITH THE APPLIANCE BODY, IT IS RECOMMENDED THAT THE WALLS OF THE APPLIANCE ENCLOSURE BE "FINISHED" (I.E.: DRYWALL / SHEETROCK), AS YOU WOULD FINISH ANY OTHER OUTSIDE WALL OF A HOME. THIS WILL ENSURE THAT CLEARANCE TO COMBUSTIBLES IS MAINTAINED WITHIN THE CAVITY.

A MINIMUM OF 6 INCHES TO COMBUSTIBLE MATERIALS IS REQUIRED TO BOTH SIDES OF THE APPLIANCE, SEE "MINIMUM CLEARANCE TO COMBUSTIBLES" SECTION.

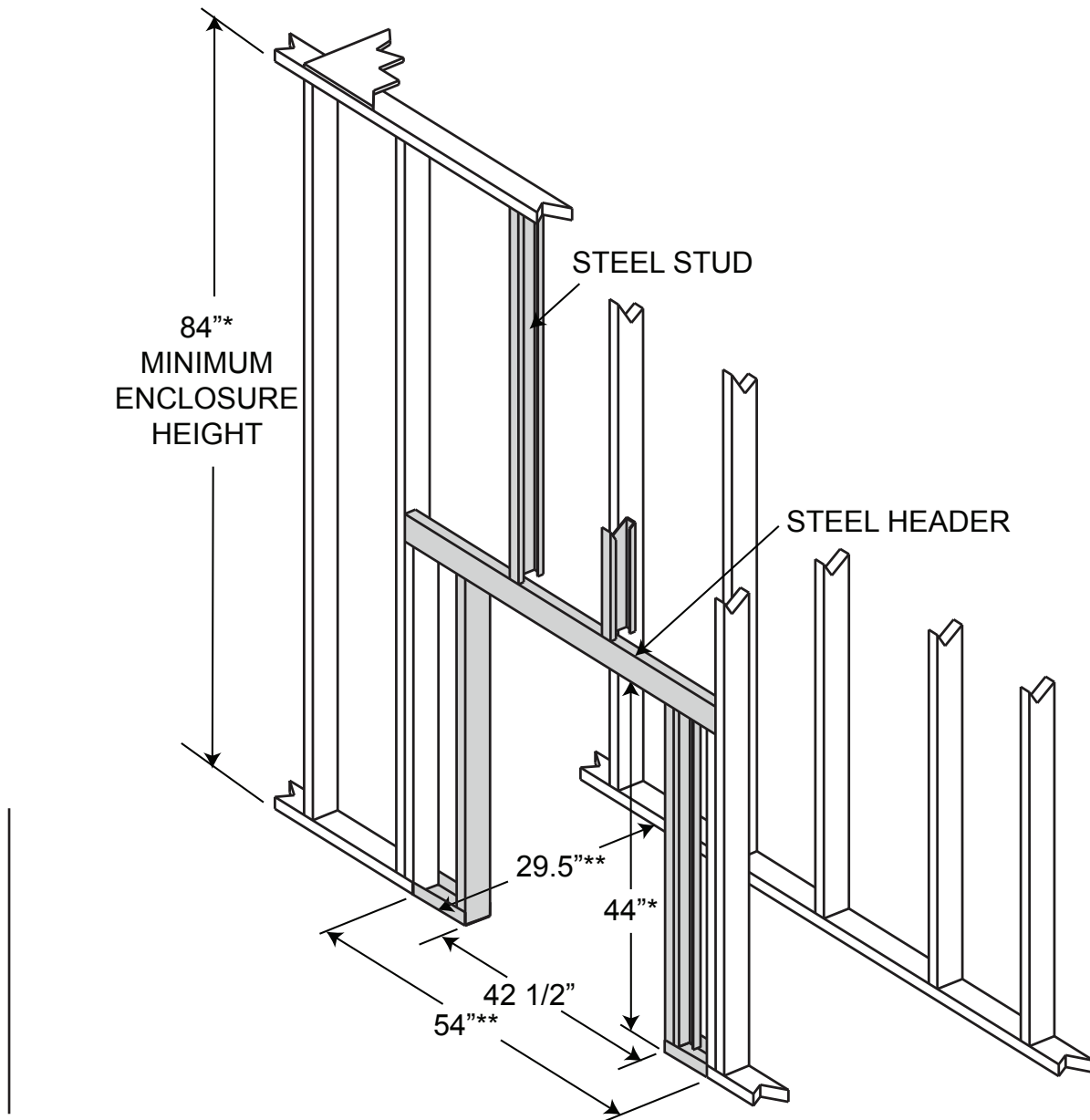

* Allow for finished floor and hearth thickness when setting these dimensions.

** When constructing the enclosure allow for finishing material thickness and to maintain clearances.

! WARNING

USE ONLY A NON-COMBUSTIBLE MATERIAL TO FINISH THE FACE OF THE APPLIANCE. A NON-COMBUSTIBLE MATERIAL SUCH AS CEMENT BOARD IS REQUIRED FOR THIS PURPOSE.

VENTILATION OPENINGS ARE REQUIRED IN ENCLOSURES UP TO 96" HIGH. THEY ARE RECOMMENDED FOR ALL ENCLOSURES.

ABOVE 84" COMBUSTIBLE FINISHING MATERIALS MAY BE USED ON THE FRONT FACE.

DO NOT INSULATE AROUND THE APPLIANCE.

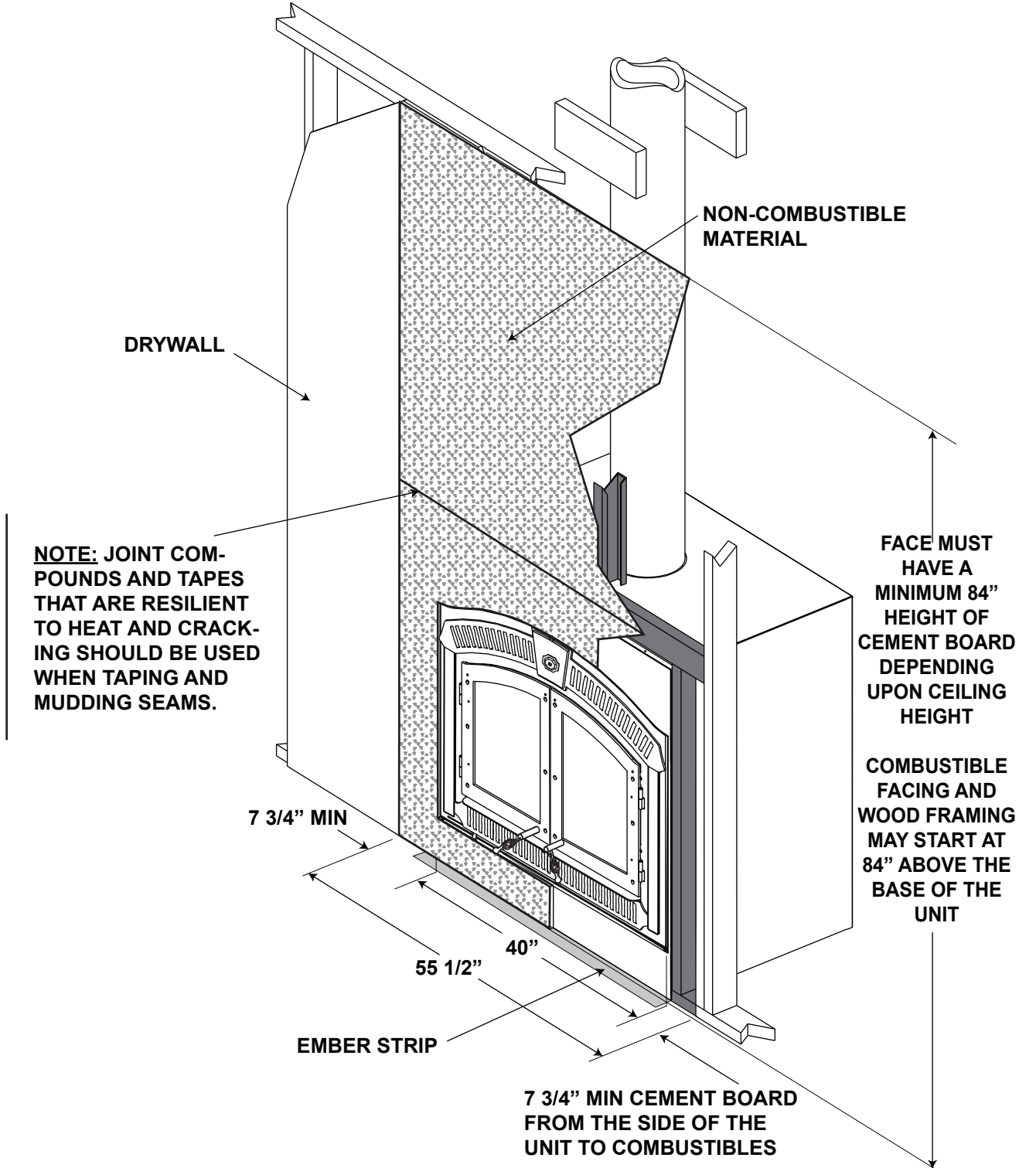

6.3 ENCLOSURE VENTILATION

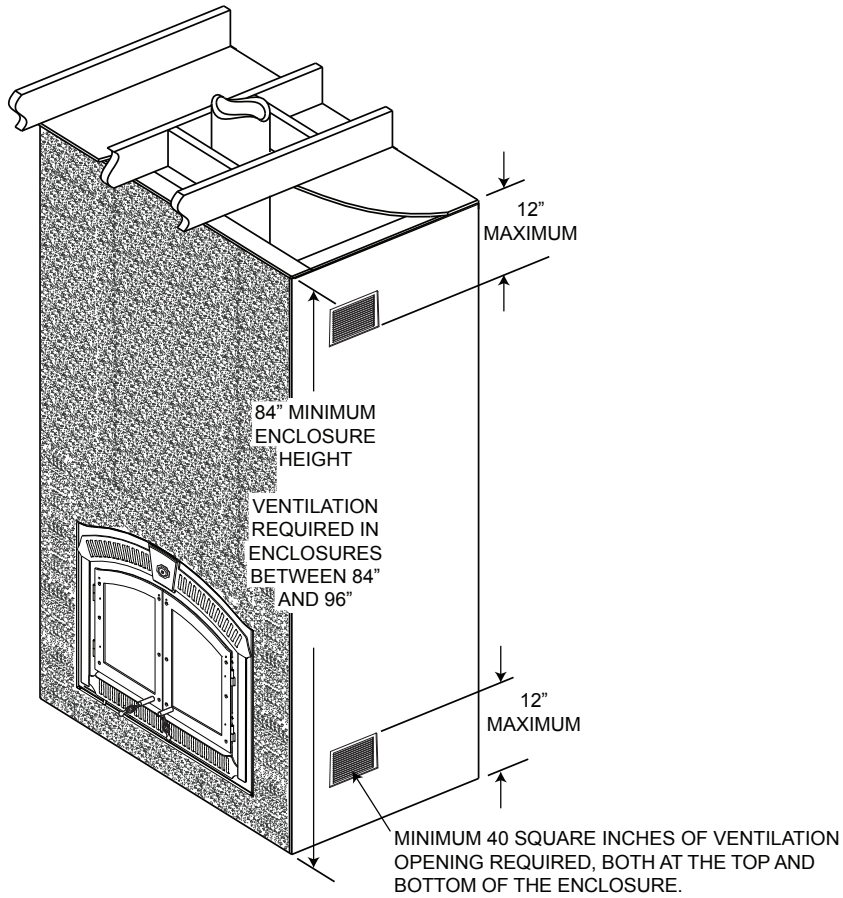

NOTE: As an alternate to grates a 1" x 40" wide gap can be left in the bottom and top of any finishing material to circulate the air from the floor, around the appliance and out the top.

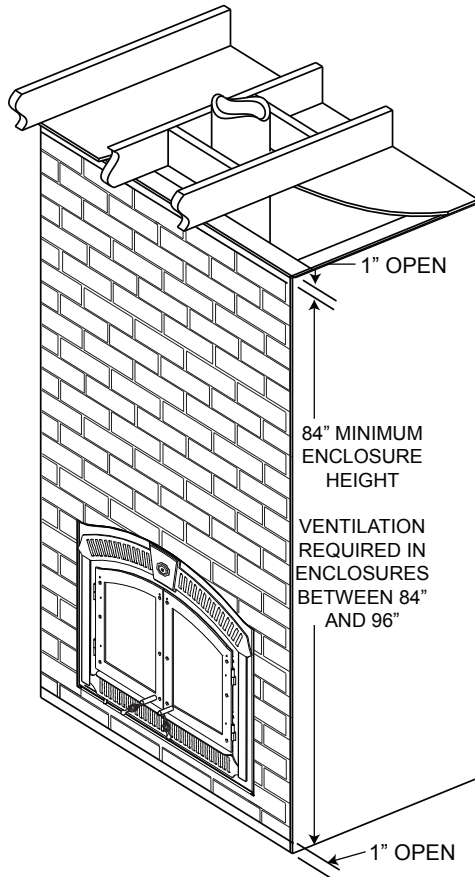

6.4 MINIMUM MANTEL CLEARANCES

! WARNING

FACING, MANTEL AND / OR FINISHING MATERIALS MUST NOT INTERFERE WITH AIR FLOW THROUGH AIR OPENINGS, LOUVRES, OPERATION OF LOUVRES OR DOORS OR ACCESS FOR SERVICE.

An optional combustibile mantel must be a minimum of 12" above the top of the faceplate and not to extend more than 2" from the surface. See chart below for further information.

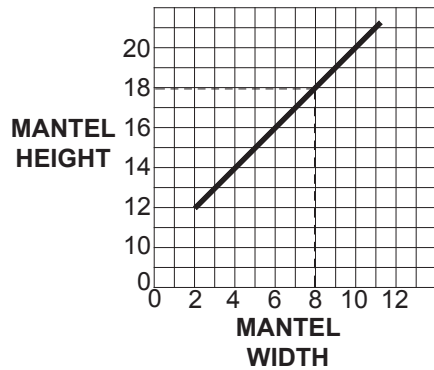

MANTEL DIMENSIONS		
Ref	Height	Depth
A	37 3/16"	
B	12"	2"
C	14"	4"
D	16"	6"
E	18"	8"

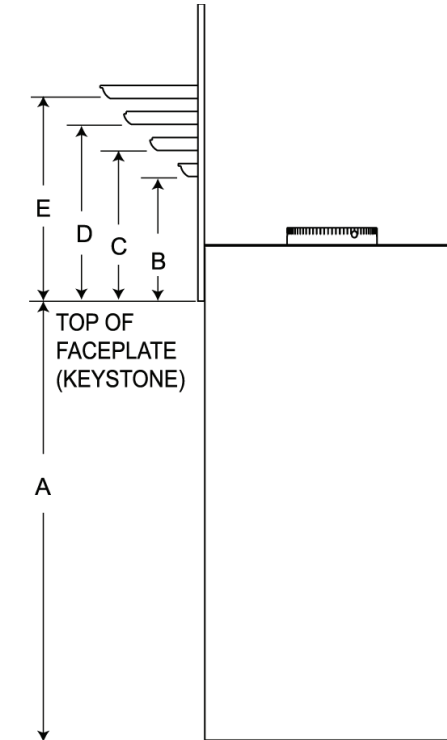

7.0 FINISHING

7.1 BAFFLE AND INSULATION BLANKET INSTALLATION

! WARNING

OPERATION OF THE APPLIANCE WITHOUT THE BAFFLES CAN RESULT IN EXCESSIVE TEMPERATURES THAT COULD DAMAGE THE APPLIANCE, CHIMNEY AND THE SURROUNDING ENCLOSURE.

The NZ3000 contains two identical baffle pieces. Lay the first piece to the back of the appliance on top of the Secondary Air Tubes and interlock the second piece as illustrated.

NOTE: Insulation blanket lays flat on top of baffle filling any gaps around baffle.

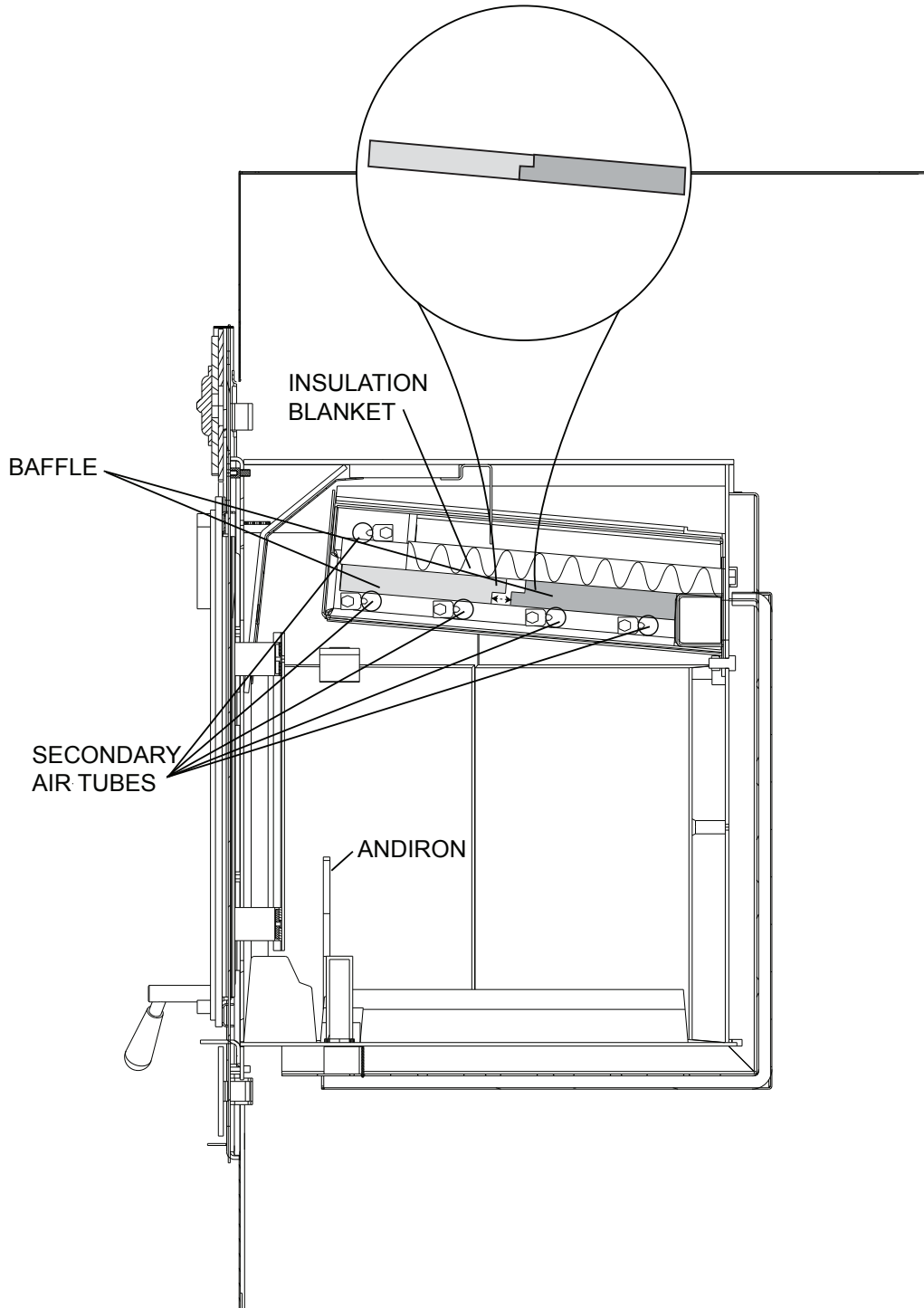

7.2 FACE PLATE, UPPER GRILLE, KEYSTONE AND DOOR INSTALLATION

7.2.1 FACEPLATE, HINGE, ASH LIP AND AIR CONTROL ARM INSTALLATION

NOTE: The faceplate is shipped with the upper and lower grilles assembled. Remove both grilles before proceeding.

- A. Assemble the air control arm by removing the 2nd screw, rotating the arm in line and re-installing the screw.
- B. Install the ash lip.

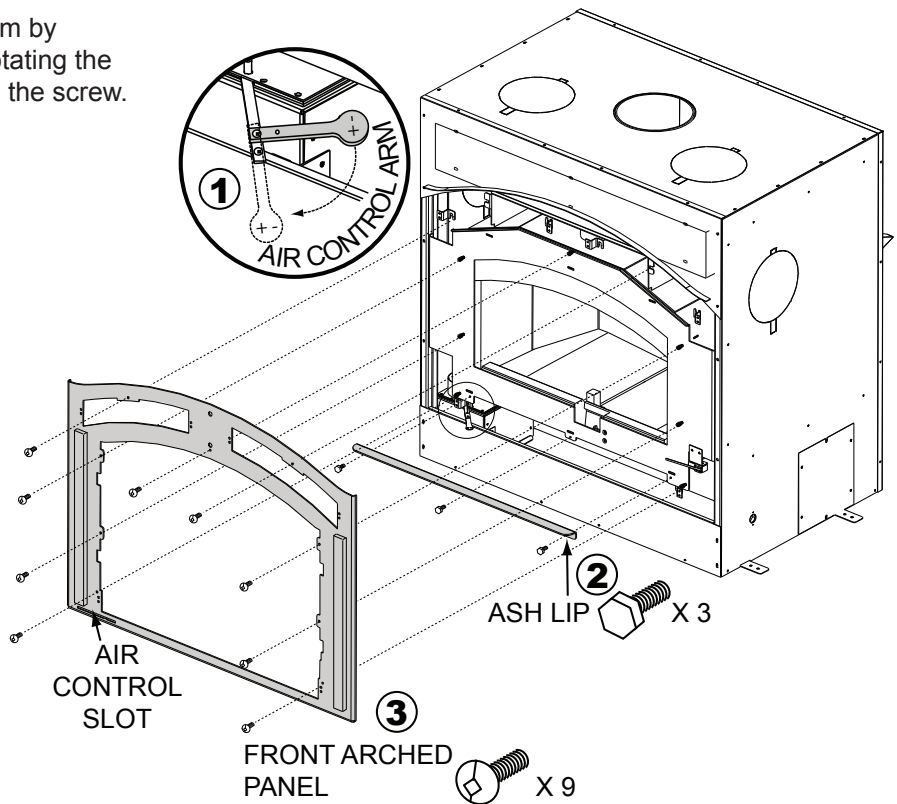

7.2.2 H336-WI DOOR ASSEMBLY

Install hardware as shown in the order of 1 through 4.

NOTE: Doors may need to be adjusted to ensure air tightness.

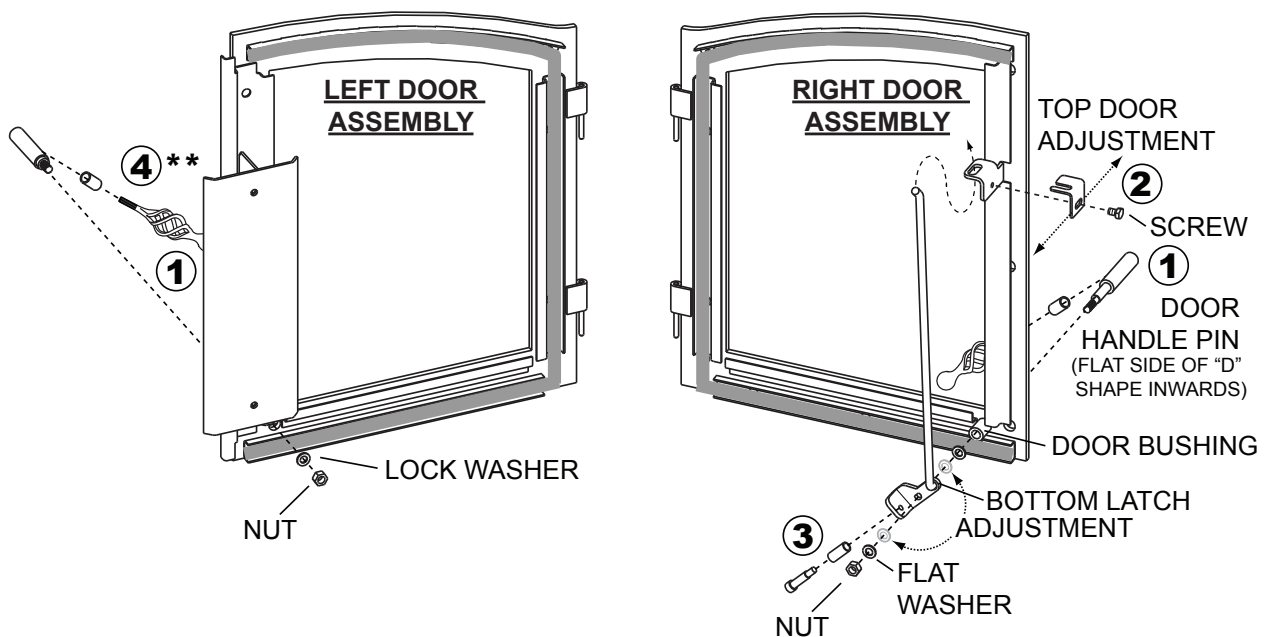

** The final angle of the left door handle should mirror the right door handle in the closed position. Tighten the nut to secure the handle at the desired angle.

7.2.3 DOOR AND TRIM INSTALLATION

- A. Install hinges to firebox front.
(Later adjustment may be required - see 4).
- B. Install the top trim.
- C. Install the bottom trim.
- D. Install doors.
Adjust to desired fit.

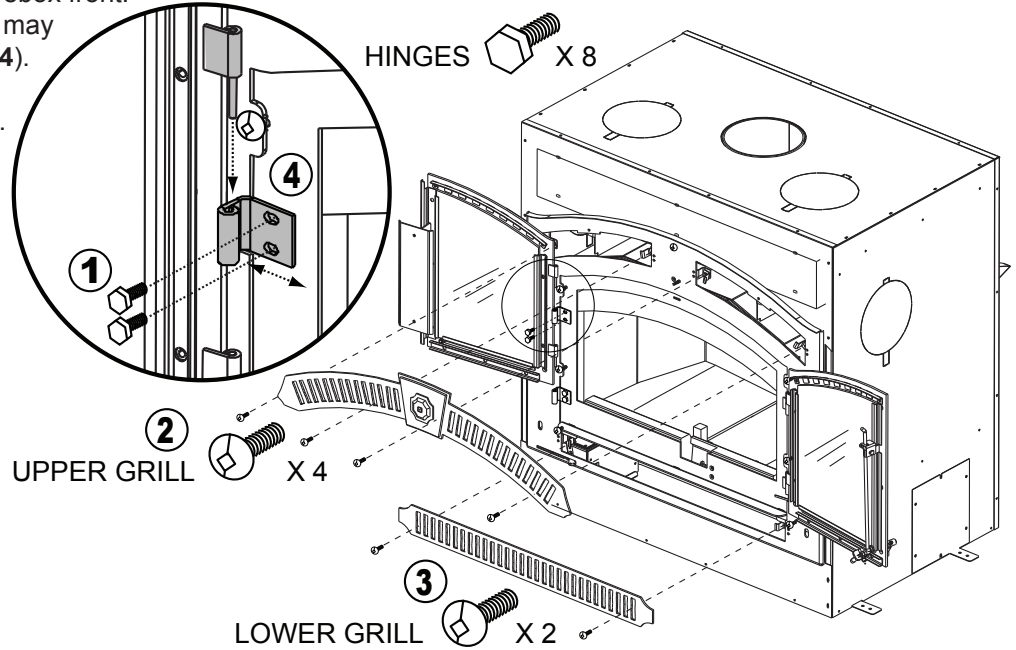

Bottom Latch Adjustment:

For desired tightness, place appropriate quantity of washers between latch and door. See "H336-WI DOOR ASSEMBLY" section.

Top Door Adjustment:

Adjust to tighten the top of the door. See "H336-WI DOOR ASSEMBLY" section.

6.2.5 OPTIONAL SPARK SCREEN INSTALLATION

! WARNING

NEVER LEAVE APPLIANCE OPERATING UNSUPERVISED WITH SPARK SCREEN IN PLACE. USE CAUTION WHEN PLACING THIS SPARK SCREEN ON AN OPERATING APPLIANCE. TURN OFF THE BLOWER BEFORE OPERATING WITH THE SPARK SCREEN.

USE ONLY WOLF STEEL APPROVED OPTIONAL ACCESSORIES AND REPLACEMENT PARTS WITH THIS APPLIANCE. USING NON-LISTED ACCESSORIES AND REPLACEMENT PARTS (BLOWERS, DOORS, LOUVRES, TRIMS, GAS COMPONENTS, VENT COMPONENTS, ETC.) COULD RESULT IN A SAFETY HAZARD AND WILL VOID THE LIMITED LIFETIME WARRANTY.

Use the spark screen when you are in the room to enjoy the ambience of an open, wood crackling fire.

Medium sized wood loads should be used to prevent logs from rolling against the spark screen.

Chimney action may not allow the spark screen to be used in some installations due to the resulting smoke spillage.

Wood will burn at a faster rate and heat output will be less with the spark screen compared to the appliance operation with the glass doors closed.

Do not use any type of wood that produces excess sparks. (ie. Cedar)

Spark screen must be removed in order to close the glass operating doors.

- A. Open the glass operating doors.
- B. Tilt the top of the spark screen forward and slide the top clip behind the top edge of the appliance opening.
- C. Swing the bottom of the spark screen into position, allowing the bottom clip to rest on the bottom opening.

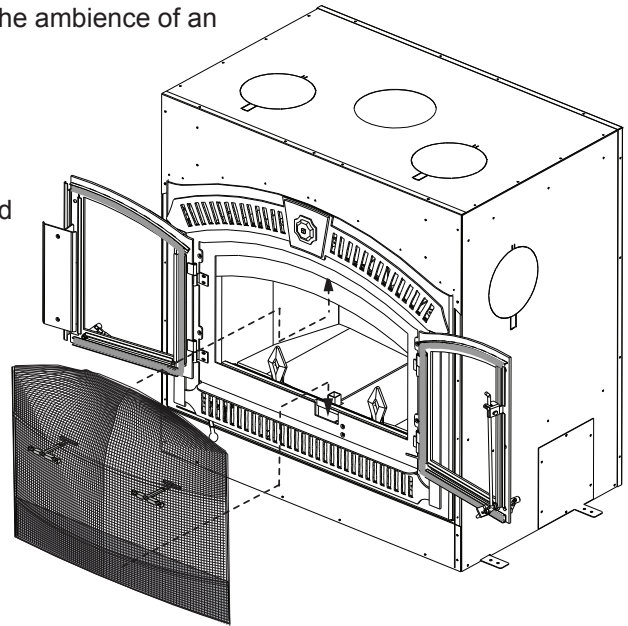

7.3 OPTIONAL NZ64 BLOWER INSTALLATION

! WARNING

ALL WIRING SHOULD BE DONE BY A QUALIFIED ELECTRICIAN AND SHALL BE IN COMPLIANCE WITH LOCAL CODES AND WITH THE NATIONAL ELECTRIC CODE ANSI/NF NO. 70-CURRENT (IN THE UNITED STATES), OR WITH THE CURRENT CSC22.1 CANADIAN ELECTRIC CODE (IN CANADA).

This appliance is supplied with two micro (pressure) switches (*the blower on high draws 3.0 amps using 120V (approx. 360w)*) and a thermally activated switch.

Ensure that the pressure switch actuating arm protrudes through the faceplate when installed and moves freely.

The blower will only operate when the doors are fully closed and the air control is not set to it's "super low" burn rate.

PRESSURE SWITCH
ACTUATING ARM

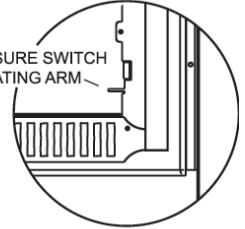

BLOWER INSTALLATION

NOTE: Consideration should be made for blower location as the closer to the appliance the greater the air flow noise will be.

- A. Position the blower to an inside or outside wall into a framed opening 12 ³/₈" wide by 10 ¹/₂" high. (Outside wall not recommended in colder climates as cold air may be drawn into the house even when the blower is off.)

The blower housing should be installed onto a level surface large enough to support the blower assembly. Allow for finishing material when securing the blower housing, as the grille mounts to the housing.

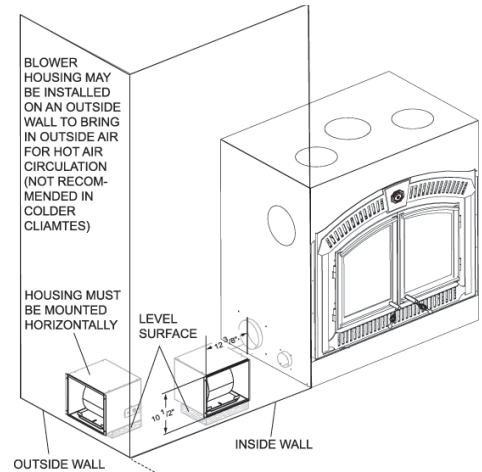

COLLAR INSTALLATION

- B. Determine which side of the appliance the blower is to be located on. Remove and discard the cover plate and install the 6" collar.

Secure by reaching through the collar and bending the tabs.

Use sealant to ensure that the connection is air tight.

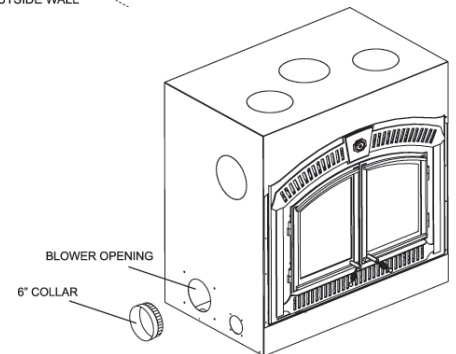

ELECTRICAL CONNECTION

- C. Remove the junction box covers on the appliance and the blower.
Removing the junction box cover on the appliance exposes 4 black, labeled wires:

Two wires labelled "by-pass" - go to by-pass (summer) switch (not supplied - overrides the thermally activated switch enabling the user to run the blower without heat).

IMPORTANT: If the by-pass, (summer) switch is not desired, terminate the wires by attaching wire nuts to by-pass (summer) switch wire leads separately (do not connect together).

One wire labelled "blower" - connects to KB-35 rheostat and then KB-35 connects to white blower wire.

One wire labelled "L1" - connects to power (hot lead).

- Removing the junction box cover on the blower exposes 3 coloured wires:

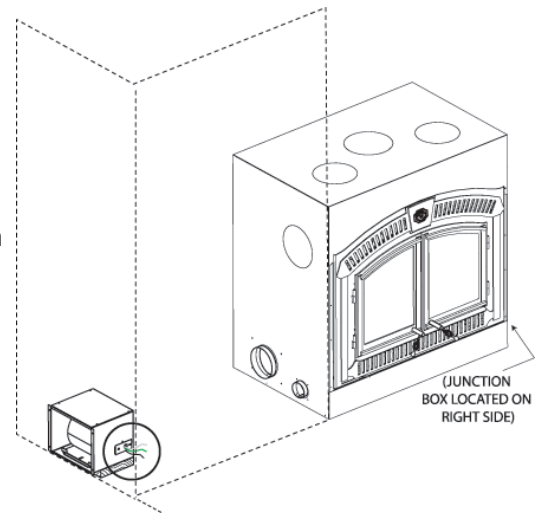

One black wire
- connects to power "L2"
(neutral lead).

One green wire
- connects to ground.

One white wire
- connects to KB-35
rheostat or wall switch
or thermostat.

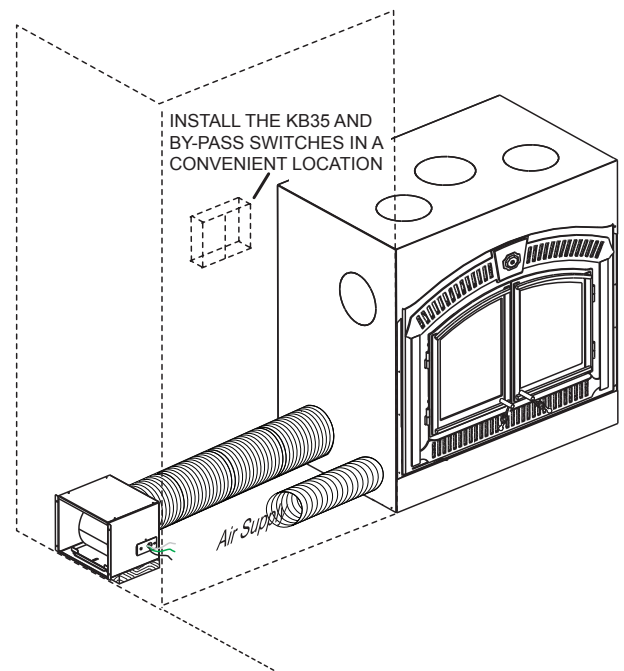
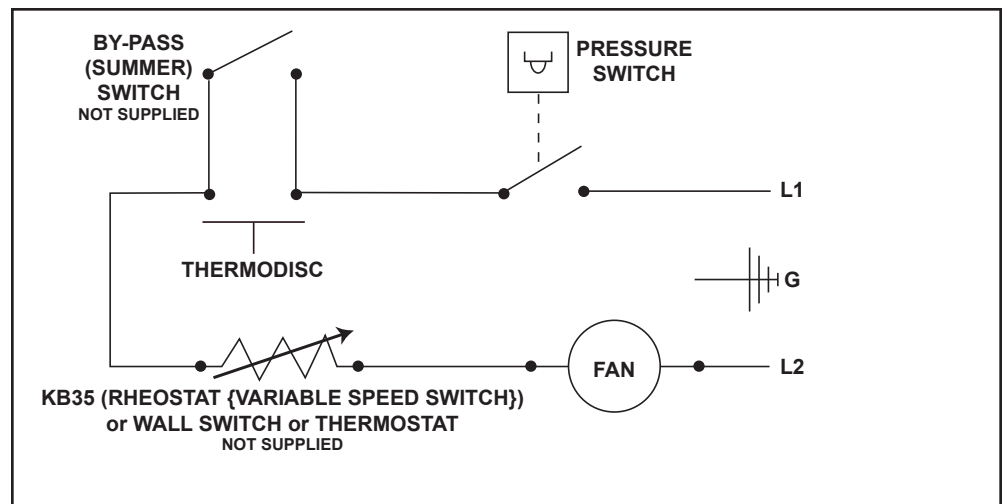

VENT CONNECTION

- D. Connect the 6" liner to the 6" appliance collar and blower collars. Secure using 3 screws on each end and seal with caulking. Liner stretches to a maximum of 10'.

GRILL AND FILTER INSTALLATION

- E. Insert the filter into the grill. Foam gasket (1/2" weather stripping) between the grill and blower housing is recommended, but not supplied. The blower filter is washable. The bottom lip of the grill latches over the bottom lip of the housing. Use two screws to secure the top of the grill to the facing.

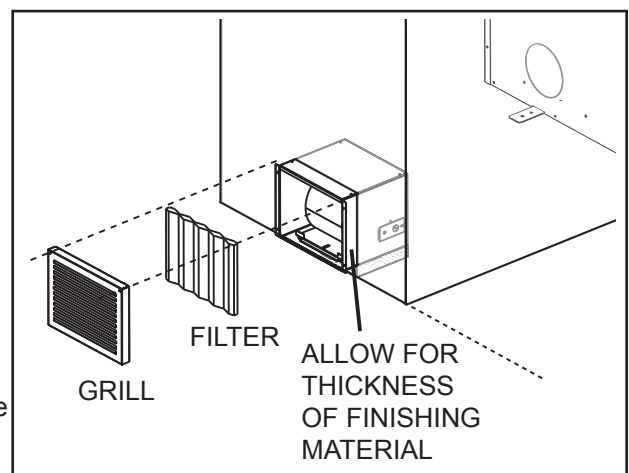

7.4 NZ64 BLOWER REPLACEMENT

- A. Remove the grill and filter by removing the 2 securing screws.
- B. Remove the nut securing the blower bracket to the housing.
- C. Lift the handles to pull the blower and bracket off of the stud.
- D. Slide the bracket and blower out of the housing.
- E. Disconnect the wire connector from the blower.
- F. Remove the old blower from the bracket by removing the four screws.
- G. Secure the new blower to the existing bracket using the four screws.
- H. Slide the new blower/bracket assembly into the housing. Ensure that the blower bracket slides into the clips at the back of the housing on either side.
- I. Push the assembly into the housing as far in as possible.
- J. Secure the assembly to the housing using the nut removed in step B.
- K. Re-secure the grill by replacing the 2 securing screws.

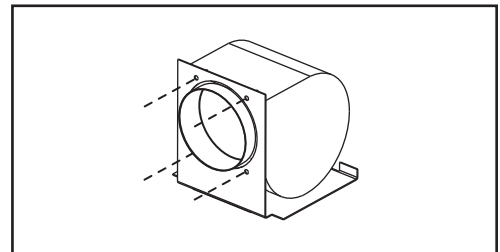
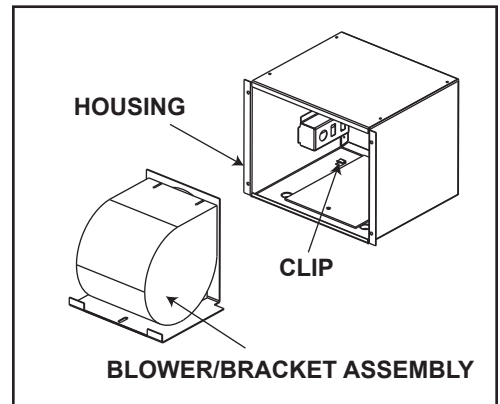
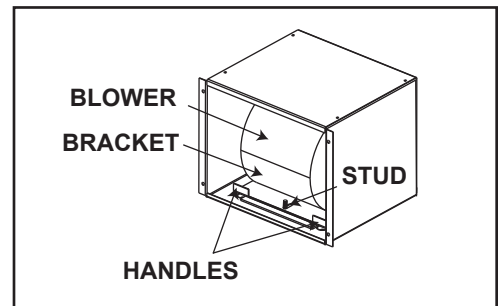
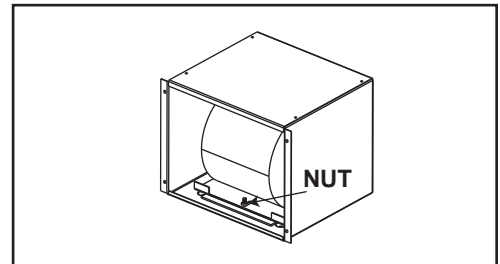
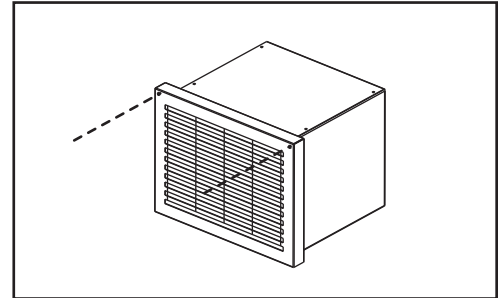

8.0 OPERATING INSTRUCTIONS

Expansion / contraction noises during heating up and cooling down cycles are normal and to be expected.

TIPS FOR BURNING:

- Create a large fire to heat up the appliance before adjusting to a slower burn.
- To create a large, quick burning fire, use small pieces of wood.
- For a lower, but extended burn, stack larger pieces of wood close together.
- For long burns, leave a 1-2" bed of ashes.
- Burn dry wood only.
- With the exception of overnight burns, create large, quick burning fires whenever possible. Smaller, slow burning fires, using large logs, cause the glass to become dirty. Larger, quick burning fires using medium sized wood to refuel frequently are much more efficient.

8.1 APPLIANCE OPERATION

Primary combustion air enters through the air control inlet box regulated by a draft control, travels up the side through a duct and enters the top centre of the combustion chamber into a preheating airwash located across the top and then down the window to feed the fire and also to ensure that the glass remains clean.

Secondary air feeds directly into the combustion chamber at hearth level then travels to the secondary air chamber and shoots out to oxidize the gases rising to the smoke exit.

8.2 OPERATING SOUNDS AND SMELLS

A slight humming sound may be heard depending on the location of the blower. This sound may be minimized by turning down the blower speed.

When first installed, the appliance and the steel are cold and must become hot before the appliance will function well. During the break-in period (the first 2 or 3 fires) create only small, hot fires using kindling; this will allow the firebrick to cure. Do not be alarmed if small hairline cracks develop in the firebrick. This is a normal occurrence and does not pose a safety hazard. The paint may also smell a little for the first few fires as it cures and you may wish to open a door or window to alleviate the smell.

There are many different ways to start a fire, review the hints and warnings in this section to ensure the fire is started properly.

8.3 STARTING A FIRE

 WARNING
ALWAYS OPERATE THIS APPLIANCE WITH THE DOOR CLOSED AND LATCHED EXCEPT DURING START UP AND RE-FUELING OR WHEN USING THE SPARK SCREEN. ALWAYS WEAR GLOVES TO PREVENT INJURY. DO NOT LEAVE THE FIRE UNATTENDED WHEN THE DOOR IS UNLATCHED OR WHEN USING A SPARK SCREEN AS UNSTABLE WOOD COULD FALL OUT OF THE FIRE CHAMBER CREATING A FIRE HAZARD TO YOUR HOME.
NEVER LEAVE CHILDREN UNATTENDED WHEN THERE IS A FIRE BURNING IN THE APPLIANCE.
DO NOT START A FIRE WITH CHEMICALS OR FLUIDS SUCH AS GASOLINE, ENGINE OIL, ETC.

Make sure the air control lever is on high (far left position). You may also open the doors 1" to 2" during the first five minutes of start-up, if additional air is needed see "COMBUSTION AIR" section.

Never use gasoline, gasoline-type lantern fuel, kerosene, charcoal lighter fluid, or similar liquids to start or freshen-up a fire in this appliance. Keep all such liquids well away from the appliance while it is in use. If using a firestarter, use only products specifically designed for appliances - follow the manufacturer's instructions carefully.

Remove all source of gasoline or other flammable vapours and liquids in the vicinity of this or other appliances prior to lighting.

Use plenty of newspaper and kindling to ensure the appliance reaches a proper temperature. Once the kindling is burning rapidly, place a few larger pieces of wood onto the fire.

Tip: When first lighting a fire, if the smoke is not quickly drawn into the chimney, there may be a downdraft or cold air in the chimney. By first burning large amounts of crumpled newspaper, the chimney will get heated and the smoke will quickly vent up the chimney.

8.4 DRAFT CONTROL



WARNING

ALWAYS OPERATE THIS APPLIANCE WITH THE DOOR CLOSED AND LATCHED EXCEPT DURING START-UP AND RE-FUELING.

Draft is the force which moves air from the appliance up through the chimney. The amount of draft in your chimney depends on the length of the chimney, local geography, nearby obstructions and other forces. Adjusting the draft control regulates the temperature. The draft can be adjusted from a low burn rate with the air control on the low setting to a fast burn rate with the air control on the high setting (far left position). Inadequate draft may cause back-puffing into the room and may cause plugging of the chimney. Too much draft may cause an excessive temperature in the appliance, glowing red appliance parts or an uncontrollable burn which can all lead to a chimney fire or a permanent damage to the appliance.

8.5 STARTING THE FIRE

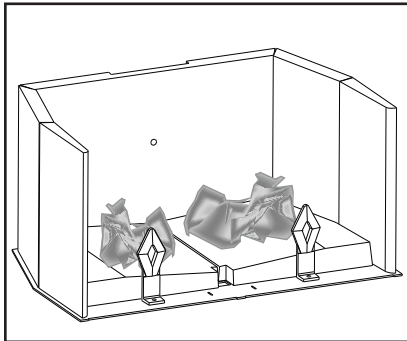

A. To start, a brisk fire is required. Roll up some newspaper (loosely crumpled), light it and place it near the appliance flue until the chimney begins to draw.

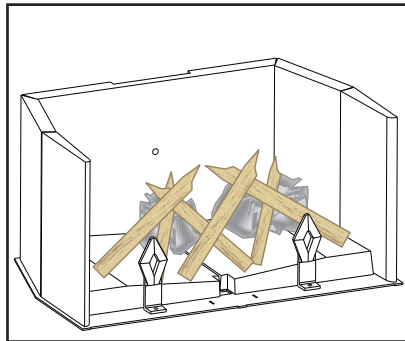

B. Cover with dry kindling.

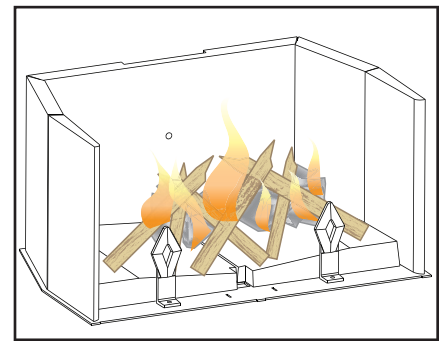

C. Fully open the draft control. See "**OPERATING INSTRUCTION**" section. Light the paper and leave the door slightly ajar (one to two inches) until all kindling is burning.

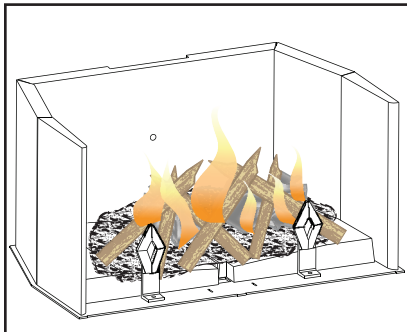

D. To maintain a brisk fire, a hot coal bed must be established and maintained.

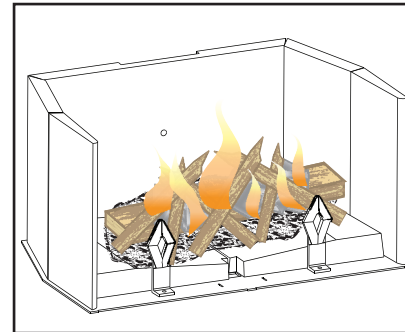

E. Slowly add larger wood (2x4 size pieces). Lay the pieces length wise from side to side in the hot coal bed with a shallow trench between, so that the primary air can flow directly into this trench and ignite the fuel above.

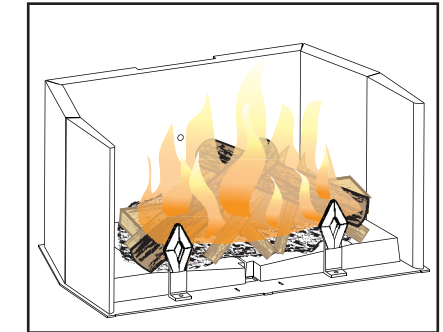

F. When the fire seems to be at its peak, medium sized logs may be added. Once these logs have caught fire, carefully close the doors.

When a fire is burning, open the doors slowly to avoid drawing smoke into the room.

Closing the doors too quickly after refuelling will reduce the firebox temperature and may result in an unsatisfactory burn.

- G.** As soon as the doors are closed, you will observe a change in the flame pattern. The flames will get smaller and lazier because less oxygen is getting into the combustion chamber. The flames, however, are more efficient. The flames will remain lazy but become larger again as soon as the firebricks have been heated thoroughly and the chimney becomes heated and provides a good draft.
- H.** With the doors opened the fire is wastefully drawing heated room air up the chimney, certainly not desirable. Always operate with the doors fully closed once the medium sized logs have caught fire.

You can now add larger pieces of wood and operate the appliance normally. Once the appliance is entirely hot, it will burn very efficiently with little smoke from the chimney. There will be a bed of hot coals in the firebox so you can safely fill the firebox with wood to the top of the andirons.

Can't get the appliance operating? Use more kindling and paper. Assuming the chimney and vent are sized correctly and there is sufficient combustion air, the lack of sufficiently *dry* quantities of *small* kindling is the problem. *Thumb size* is a good gauge for small kindling diameter.

Can't get heat out of the appliance? One of two things may have happened. The appliance door may have been closed prematurely and the appliance itself has not reached optimum temperature. Re-open the door and/or draft control to re-establish a brisk fire. The other problem may have been wet wood. The typical symptom is sizzling wood and moisture being driven from the wood.

NOTE: Appliances surrounded by solid rock or brick, will experience a longer heat up period as those materials absorb the heat being generated.

OPERATING WITH DOOR CLOSED

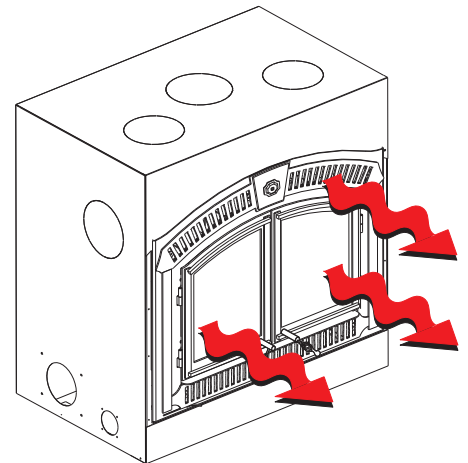

OPERATING WITH DOOR OPEN

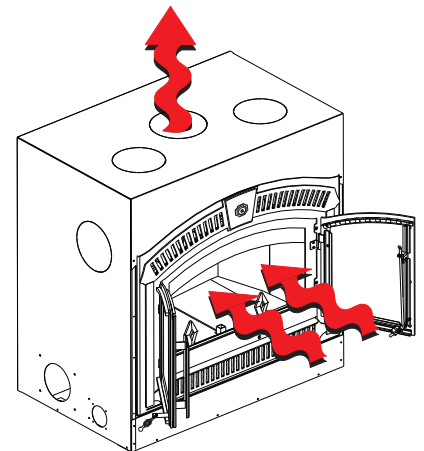

! WARNING

BURNING YOUR APPLIANCE WITH THE DOORS OPEN OR AJAR CREATES A FIRE HAZARD THAT MAY RESULT IN A HOUSE AND OR CHIMNEY FIRE.

8.6 FUEL LOADING AND BURN CYCLE

! WARNING

**BURN WOOD BEHIND THE LOG RETAINER DIRECTLY ON THE FIREBRICKS.
DO NOT USE ELEVATED GRATE OR OTHERWISE RAISE THE FIRE.**

**DO NOT STORE WOOD WITHIN APPLIANCE INSTALLATION CLEARANCES OR WITHIN THE SPACE
REQUIRED FOR RE-FUELING AND ASH REMOVAL.**

The bricks will be nearly all white and the glass mostly clear. The whiteness of the bricks and the cleanness of the glass are good indicators of your operating efficiency.

Not enough heat is produced when only one or two pieces of wood are burned.

A minimum of three pieces are needed to encase a bed of coals that sustains the fire. Loosely stacked wood burns quicker than a tightly packed load.

Wood burns in cycles rather than giving a steady output of heat. It is best to plan these cycles around your household routine so that only enough coals are left to start the next load. In the evening load your appliance at least a half-hour before bed to ensure the fire is hot enough to close the draft control for an overnight burn.

Burn only dry seasoned wood. It produces more heat and less soot or creosote. Do not burn ocean beach wood. Its salt content can produce a metal eating acid.

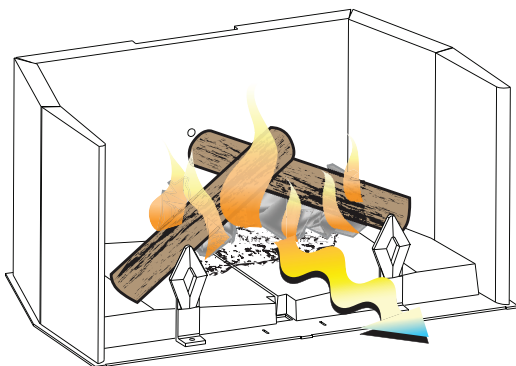

INSUFFICIENT FIREWOOD



SUFFICIENT FIREWOOD

8.7 RE-LOADING THE APPLIANCE

When refuelling open the door slowly to prevent smoke spillage. Use a pair of long appliance gloves when feeding the fire. Keep a small steel shovel nearby to use as a poker and to remove ashes. Do not store wood within 4 feet (1m) of the appliance.

Follow the directions below to minimize smoke spillage while re-loading the appliance.

- A. Move the air control to high.
- B. Open the door slightly. Allow the airflow inside the firebox to stabilize before opening the doors fully.
- C. Load wood to the top of the cast retainers and burn at a medium low setting.

! WARNING

**BURNING WET, UNSEASONED WOOD CAN CAUSE EXCESSIVE CREOSOTE ACCUMULATION. WHEN
IGNITED IT CAN CAUSE A CHIMNEY FIRE THAT MAY RESULT IN A SERIOUS HOUSE FIRE.**

8.8 FLASH FIRES

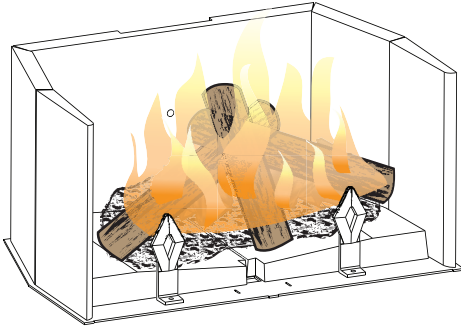

A flash fire is a small fire burned quickly when you don't need much heat. After your kindling has "caught", load at least 3 pieces of wood, stacked loosely. Burn with the draft control fully open or closed only slightly.

8.9 OVERNIGHT BURN

- A. Get the appliance hot by moving the air control to high and letting the appliance burn for 15 minutes.
- B. Load your larger pieces of wood compactly, packed close enough to prevent the flames from penetrating it completely.
- C. After approximately 30 minutes, depending on the size of the load, reduce the draft control setting making sure that the fire is not extinguished.
- D. In the morning the appliance should still be hot, with embers in the coal bed. Stir the coals and load small pieces of wood to re-ignite the fire, if desired.

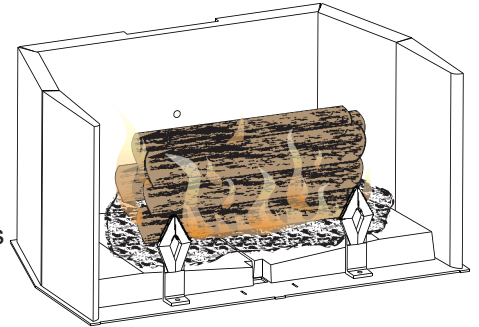

NOTE: Differences in chimney height and draft may lower overall burn times.

DO NOT OVERFIRE THE APPLIANCE! Overfiring can occur by burning large amounts of smaller wood pieces or vigorously burning large loads of wood with the draft control on "HIGH" (fully open) for long periods of time (one or two hours).

8.10 ASH REMOVAL PROCEDURES

! WARNING

IMPROPER DISPOSAL OF ASHES RESULT IN FIRES. DO NOT DISCARD ASHES IN CARDBOARD BOXES, DUMP IN BACK YARDS, OR STORE IN GARAGES.

IF USING A VACUUM TO CLEAN UP ASHES, BE SURE THE ASHES ARE ENTIRELY COOLED. USING A VACUUM TO CLEAN UP WARM ASHES COULD CAUSE A FIRE INSIDE THE VACUUM.

A bed of ashes approximately 1" deep should be left on the firebox bottom to help maintain a hot charcoal bed. When the fire has burned down and cooled, remove any excess ashes. To remove the ash, follow the directions below.

- A. After the last coal has extinguished, let the appliance cool at least two hours.
- B. Open the appliance doors.
- C. Scoop the ash from the firebox into a metal, airtight, container with a lid. Cover the container with the lid and move the container away from the appliance onto a suitable non-combustible surface to ensure the ashes cool. Dispose of the ashes.

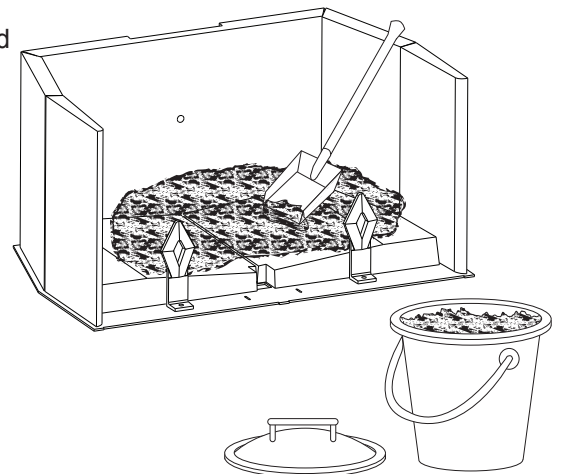

9.0 MAINTENANCE

9.1 RUN-AWAY OR CHIMNEY FIRE

WARNING

A CHIMNEY FIRE CAN PERMANENTLY DAMAGE YOUR CHIMNEY SYSTEM. THIS DAMAGE CAN ONLY BE REPAIRED BY REPLACING THE DAMAGED COMPONENT PARTS. CHIMNEY FIRES ARE NOT COVERED BY THE LIFETIME LIMITED WARRANTY.

CAUSES:

1. Using incorrect fuel, or small fuel pieces which would normally be used as kindling.
2. Leaving the door ajar too long and creating extreme temperatures as the air rushes in the open door.
3. Improperly installed or worn gaskets.
4. Creosote build up in chimney.

SOLUTIONS:

1. Do not burn treated or processed wood, coal, charcoal, coloured paper or cardboard.
2. Be careful not to overfire the appliance by leaving the door open too long after the initial start-up.
3. Replace worn, dried out (inflexible) gaskets.
4. Have chimney regularly cleaned.

WHAT TO DO IF A RUN-AWAY OR CHIMNEY FIRE STARTS:

1. Close the draft fully (lowest position).
2. Call the local fire department.
3. Examine the chimney, attic and roof of the house, to see if any part has become hot enough to catch fire. If necessary spray with a fire extinguisher or water from a garden hose.
4. Do not operate the appliance again until you are certain the chimney has not been damaged.

9.2 FIRE EXTINGUISHERS AND SMOKE DETECTORS

All homes with a solid fuel burning appliance should have at least one fire extinguisher in a central location, known to all, and at least one smoke detector in the room containing the appliance. If it sounds an alarm, correct the cause but do not de-activate or relocate the smoke detector.

9.3 GLASS AND GASKET REPLACEMENT

WARNING

MAKE SURE THAT THE GLASS AND GASKET ARE FULLY INSTALLED DOWN INTO THE GLASS RETAINER. IF THE GLASS PROTRUDES TOO FAR OUT OF THE RETAINER, THE GLASS WILL SHATTER WHEN THE DOOR IS CLOSED.

At the end of each burning season inspect the door gasket ensuring that it is not worn or loose. Replace with proper fiberglass rope. The purpose of door gasketing is to seal the firebox. If the doors are not sealed, air leaks into the firebox, creating a quick burning fire. This situation is not desirable for overnight or extended **burns and may even damage your appliance.**

Replace cracked or broken glass immediately. When re-installing the glass, be sure that the glass and gasket create a solid seal around door frame. Follow the instructions below for glass removal. You may require a flat tool to gently press the gasket between the glass and the door.

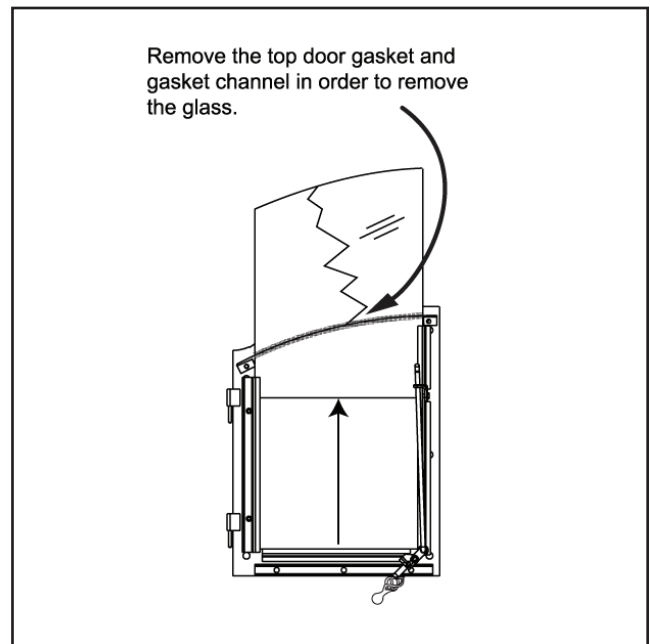
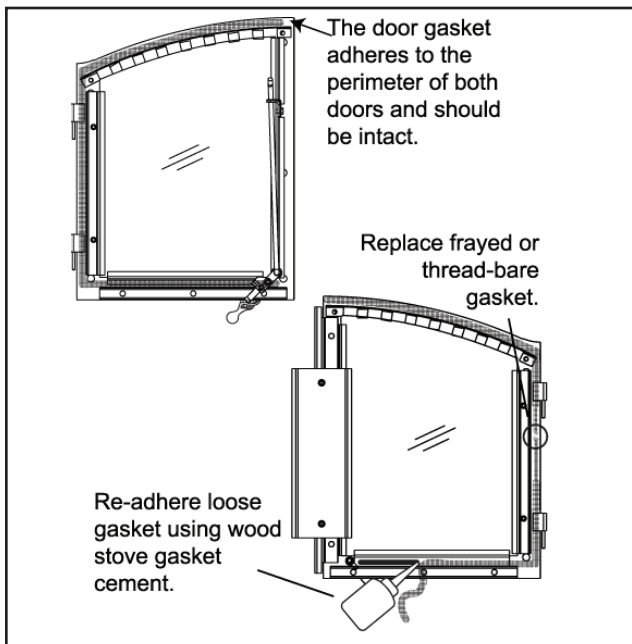

9.4 CREOSOTE FORMATION AND REMOVAL

When wood is burned slowly, it produces tar and other organic vapours which combine with expelled moisture to form creosote. These vapours condense in the relatively cooler chimney flue of a slow burning fire and when ignited, make an extremely hot fire. Check your chimney for creosote and soot build-up monthly until a safe frequency for cleaning is established (minimum once a year). If accumulation is excessive, clean the chimney. You may want to call a professional chimney sweep to clean it. Both the chimney and the appliance have to be cleaned at least once a year or as often as necessary.

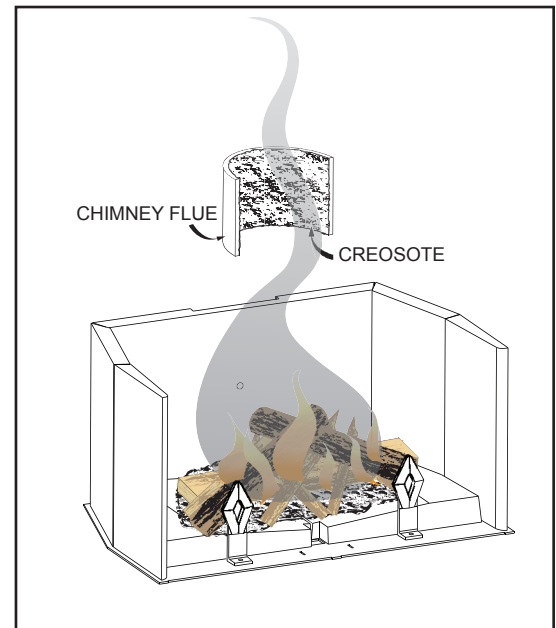

9.5 SELECTING WOOD

! WARNING

THIS APPLIANCE IS DESIGNED TO BURN NATURAL WOOD ONLY. DO NOT BURN TREATED WOOD, COAL, CHARCOAL, COLOURED PAPER, CARDBOARD, SOLVENTS OR GARBAGE. THIS APPLIANCE HAS NOT BEEN TESTED WITH AN UNVENTED GAS LOG SET. TO REDUCE RISK OF FIRE OR INJURY, DO NOT INSTALL AN UNVENTED GAS LOG SET INTO THE APPLIANCE.

HIGHER EFFICIENCIES AND LOWER EMISSIONS GENERALLY RESULT WHEN BURNING AIR DRIED SEASONED HARDWOODS, AS COMPARED TO SOFTWOODS OR TOO GREEN OR FRESHLY CUT HARDWOODS.

BURNING WET UNSEASONED WOOD CAN CAUSE EXCESSIVE CREOSOTE ACCUMULATION. WHEN IGNITED **THIS CAN CAUSE A CHIMNEY FIRE THAT MAY RESULT IN A SERIOUS HOUSE FIRE.**

Burn only dry, clean unpainted wood that has been seasoned. It produces more heat and less soot or creosote. Freshly cut wood contains about 50% moisture while after proper seasoning only about 20% of the water remains. As wood is burned, this water boils off consuming energy that should be used in heating. The wetter the wood, the less heat is given off and the more creosote is produced. Dry firewood has cracks in the end grain.

Both hardwood and softwood burn equally well in this appliance but hardwood, which is denser, will weigh more per cord and burn a little slower and longer. Firewood should be split and stacked in a manner that air can get to all parts of it and covered in early spring to be ready for burning that fall.

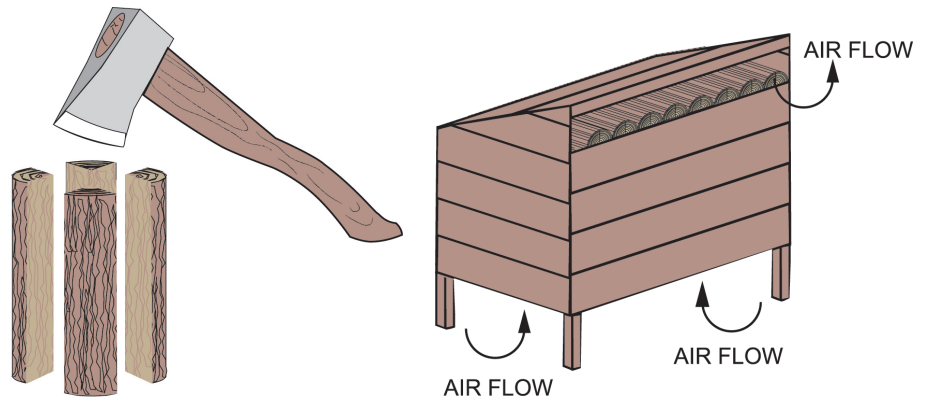

10.0 REPLACEMENTS

Contact your dealer or the factory for questions concerning prices and policies on replacement parts. Normally all parts can be ordered through your Authorized dealer / distributor.

FOR WARRANTY REPLACEMENT PARTS, A PHOTOCOPY OF THE ORIGINAL INVOICE WILL BE REQUIRED TO HONOUR THE CLAIM.

When ordering replacement parts always give the following information:

- Model & Serial Number of appliance
- Installation date of appliance
- Part number
- Description of part
- Finish

*** IDENTIFIES ITEMS WHICH ARE NOT ILLUSTRATED. FOR FURTHER INFORMATION, CONTACT YOUR AUTHORIZED DEALER.**

! WARNING

FAILURE TO POSITION THE PARTS IN ACCORDANCE WITH THIS MANUAL OR FAILURE TO USE ONLY PARTS SPECIFICALLY APPROVED WITH THIS APPLIANCE MAY RESULT IN PROPERTY DAMAGE OR PERSONAL INJURY.

41.1

Appliance AND ACCESSORY REPLACEMENT PARTS		
REF	PART NUMBER	DESCRIPTION
1	W300-0103	DOOR GLASS
2*	W562-0058	DOOR GASKET 7/8 x 43"
3*	W562-0002	DOOR GASKET - CENTRE 1/2" x 20"
4*	W010-1933	GLASS & GASKET
5*	W690-0005	120V THERMOSTAT
6	W090-0146	BRICK, FRONT LEFT
7	W090-0147	BRICK, FRONT SIDE (2PC REQUIRED)
8	W090-0148	BRICK, SIDE (2PC REQUIRED)
9	W090-0149	BRICK, REAR
10	W090-0150	BRICK, BASE RIGHT SIDE
11	W090-0151	BRICK, BASE LEFT SIDE
12	W090-0156	BRICK, FRONT RIGHT
13	W018-0116	BAFFLE (2 pc required)
14*	KB-35	VARIABLE SPEED CONTROL - INCLUDING KNOB
15*	W660-0065	HEAT SENSOR
16	W010-1776	LEFT DOOR ASSEMBLY (INCLUDES GLASS, GASKET & HANDLE / LATCH HARDWARE)
17	W010-1775	RIGHT DOOR ASSEMBLY (INCLUDES GLASS, GASKET & HANDLE / LATCH HARDWARE)
18*	W361-0082	BAFFLE BLANKET
19*	W325-0048	PRIMARY AIR CONTROL HANDLE
20	W325-0029	DOOR HANDLE - BIRD CAGE
21	W715-0773	ANDIRONS
22*	W385-0334	NAPOLEON® LOGO
23	W010-1974	SECONDARY AIR MANIFOLD (INCLUDES AIR TUBES)
24	W720-0126	SECONDARY AIR TUBE
25*	W290-0142	GASKET, SECONDARY AIR MANIFOLD
26*	W450-0028	NUT, HEX BRASS
27*	W010-1896	PILOT TUBE
28*	W615-0106	SPACER
29	W660-0079	SWITCH, PRESSURE SWING DOOR
30*	W250-0005	BLOWER FILTER
31	W305-0007	BLOWER GRILL
32	W290-0148	ANCHOR PLATE GASKET

ACCESSORIES

REF	PART NUMBER	DESCRIPTION
33	H336-WI	ARCHED DOUBLE DOORS - WROUGHT IRON FINISH
34	FPWI3	FACEPLATE ARCHED - WROUGHT IRON FINISH
35	NSK3	ARCHED SPARK SCREEN KIT
36*	NZ220	GRAVITY HOT AIR VENT KIT
37*	NM228-M	FLUE TILE SUPPORT
38	NZ64	BLOWER KIT
39*	NZ62CH	CENTRAL HEATING SYSTEM

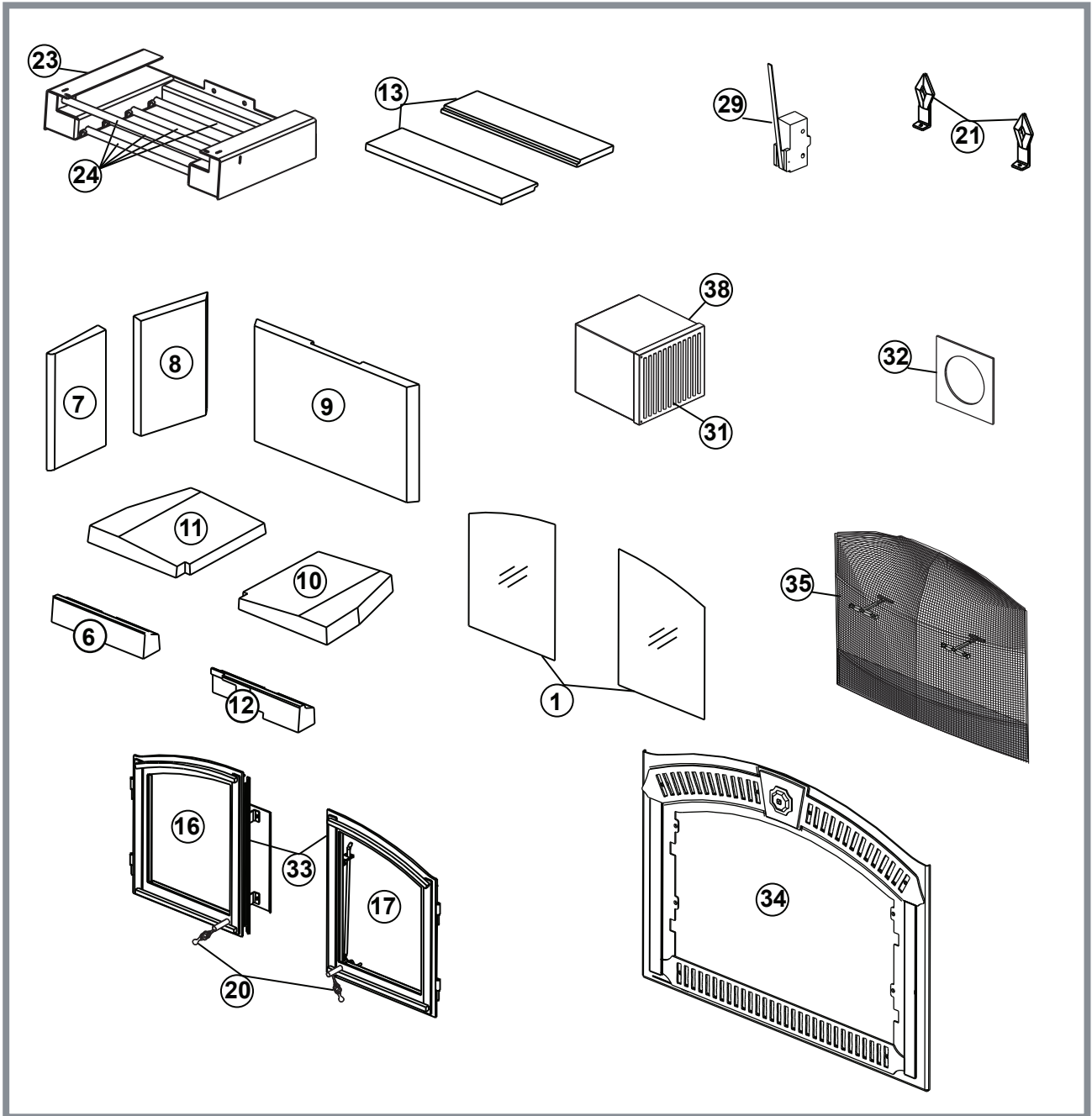

11.0 TROUBLE SHOOTING GUIDE

ALWAYS LIGHT THE PILOT WHETHER FOR THE FIRST TIME OR IF THE GAS SUPPLY HAS RAN OUT WITH THE GLASS DOOR OPENED OR REMOVED.

SYMPTOM	PROBLEM	TEST SOLUTION
Smoke enters the room during start-up.	Cold air blockage in chimney.	- Burn a piece of newspaper to establish a draft.
	Close the doors.	- If the flame is not getting enough air, first make sure the air control is open. If additional air is needed, open the doors a small crack only.
Kindling does not start - fire smolders.	Cold air blockage in chimney.	- Burn a piece of newspaper to establish a draft.
	Not enough starter paper.	- Use additional newspaper if necessary.
	Not enough air.	- First make sure the air control is fully open. If additional air is needed, a small crack in the doors is all that is needed.
Smoke enters the room while re-loading.	Insufficient draft.	- Chimney height and outside conditions can negatively affect draft. In these cases a small amount of smoke may enter the home. Adding more pipe or a draft-inducing cap may help.
Fireplace does not burn hot enough.	Wood is wet.	- See the section on "Selecting Wood" for details.
	Insufficient draft.	- Chimney height and outside conditions can negatively affect draft. In these cases a small amount of smoke may enter the home. Adding more pipe or a draft-inducing cap may help.
	Air control is not wide open.	- Make sure the air control is open all the way. Slide the control back and forth rapidly to insure the control is not stuck.
Blower does not run.	Fireplace is not up to temperature.	- This is normal. The blower will come on when the fireplace is hot.
	Electricity is cut to the blower.	- Check the household breaker or fuse to make sure it is operable.
Faceplate is cold.	This is normal.	- The air leading into the firebox could come from the exterior. In these cases this air comes into the firebox and exits the chimney. This will not damage the fireplace.
Fireplaces does not burn overnight.	The doors are not sealing.	- See the section "Door Glass / Gasket Replacement" for details.
Fireplace smoking.		

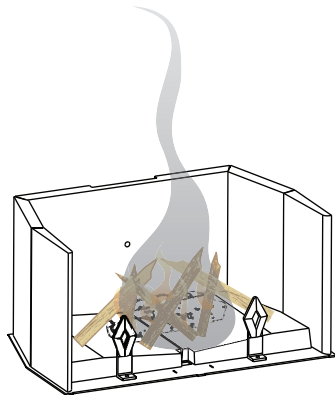
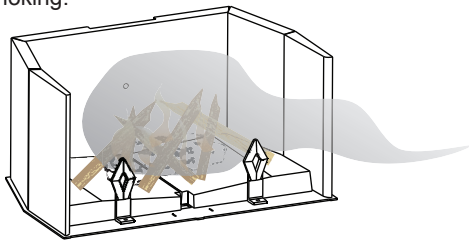

- Has the chimney had time to get hot?
- Is there adequate supply of combustion air?
- Is the outside air damper opened?
- Is the smoke passage blocked anywhere in the fireplace or chimney?
- Is the smoke flow impeded by too long of a horizontal pipe or too many bends?
- Is it a weak draft perhaps caused by a leaky chimney, a cold outside chimney, too short a chimney, or a chimney too close to a tress or a higher roof?

12.0 WARRANTY

NAPOLEON® products are manufactured under the strict Standard of the world recognized ISO 9001 : 2008 Quality Assurance Certificate.

NAPOLEON® products are designed with superior components and materials, assembled by trained craftsmen who take great pride in their work. The complete fireplace is again thoroughly inspected by a qualified technician before packaging to ensure that you, the customer, receives the quality product that you expect from NAPOLEON®.

NAPOLEON® WOOD FIREPLACE PRESIDENT'S LIFETIME LIMITED WARRANTY

The following materials and workmanship in your new NAPOLEON® wood fireplace are warranted against defects for as long as you own the fireplace. This covers: combustion chamber, heat exchanger, stainless steel baffle retainer, ceramic glass (thermal breakage only), gold plated parts against tarnishing, porcelainized enameled components, aluminum extrusion trims ash drawer and cast iron castings.

Electrical (110V) components and wearable parts such as blowers, thermal switch, switches, wiring, firebrick, and gasketing are covered and NAPOLEON® will provide replacement parts free of charge during the first year of the limited warranty.

Labour related to warranty repair is covered free of charge during the first year. Repair work, however, requires the prior approval of an authorized company official. Labour costs to the account of NAPOLEON® are based on a predetermined rate schedule and any repair work must be done through an authorized NAPOLEON® dealer.

CONDITIONS AND LIMITATIONS

NAPOLEON® warrants its products against manufacturing defects to the original purchaser only. Registering your warranty is not necessary. Simply provide your proof of purchase along with the model and serial number to make a warranty claim. Provided that the purchase was made through an authorized NAPOLEON® dealer your fireplace is subject to the following conditions and limitations:

This factory warranty is non-transferable and may not be extended whatsoever by any of our representatives.

The wood fireplace must be installed by an authorized service technician or contractor. Installation must be done in accordance with the installation instructions included with the product and all local and national building and fire codes.

This limited warranty does not cover damages caused by misuse, lack of maintenance, accident, alterations, abuse or neglect and parts installed from other manufacturers will nullify this warranty.

This limited warranty further does not cover any scratches, dents, corrosion or discoloring caused by excessive heat, abrasive and chemical cleaners nor chipping on porcelain enamel parts, nor any venting components used in the installation of the fireplace.

In the first year only, this warranty extends to the repair or replacement of warranted parts which are defective in material or workmanship provided that the product has been operated in accordance with the operation instructions and under normal conditions.

After the first year, with respect to the President's Lifetime Limited Warranty, NAPOLEON® may, at its discretion, fully discharge all obligations with respect to this warranty by refunding to the original warranted purchaser the wholesale price of any warranted but defective part(s).

After the first year, NAPOLEON® will not be responsible for installation, labour or any other costs or expenses related to the reinstallation of a warranted part, and such expenses are not covered by this warranty.

Notwithstanding any provisions contained in the President's Lifetime Limited Warranty, NAPOLEON's responsibility under this warranty is defined as above and it shall not in any event extend to any incidental, consequential or indirect damages.

This warranty defines the obligations and liability of NAPOLEON® with respect to the NAPOLEON® wood fireplace and any other warranties expressed or implied with respect to this product, its components or accessories are excluded.

NAPOLEON® neither assumes, nor authorizes any third party to assume, on its behalf, any other liabilities with respect to the sale of this product. NAPOLEON® will not be responsible for: over-firing, downdrafts, spillage caused by environmental conditions such as rooftops, buildings, nearby trees, hills, mountains, inadequate vents or ventilation, excessive venting configurations, insufficient makeup air, or negative air pressures which may or may not be caused by mechanical systems such as exhaust fans, furnaces, clothes dryers, etc.

Any damages to fireplace, combustion chamber, heat exchanger, brass trim or other component due to water, weather damage, long periods of dampness, condensation, damaging chemicals or cleaners will not be the responsibility of NAPOLEON®.

NAPOLEON® reserves the right to have its representative inspect any product or part thereof prior to honouring any warranty claim.

ALL SPECIFICATIONS AND DESIGNS ARE SUBJECT TO CHANGE WITHOUT PRIOR NOTICE DUE TO ON-GOING PRODUCT IMPROVEMENTS. NAPOLEON® IS A REGISTERED TRADEMARK OF WOLF STEEL LTD. PATENTS U.S. 5.303.693.801 - CAN. 2.073.411, 2.082.915. © WOLF STEEL LTD.

13.0 SERVICE HISTORY

Appliance Service History This heater must be serviced annually depending on usage.				
Date	Dealer Name	Service Technician Name	Service Performed	Special Concerns

