

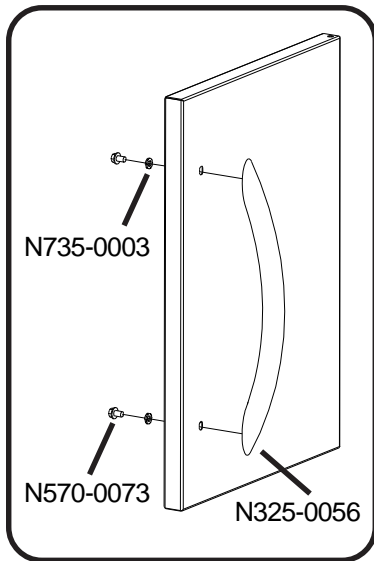

BUILT-IN ACCESSORY DOUBLE DOOR INSTRUCTIONS

The door opening required for the stainless steel double door accessory kit is as shown. The frame must be mounted in the cabinet level horizontally and vertically for the doors to close properly. The door frame must be installed squarely to prevent uneven gaps between the doors and frame. Check for squareness by measuring diagonally across the frame in both directions. Once these two measurements are equal to each other, the frame is to be considered square.

NOTE: Accessory frames overlap opening by 1 3/4" on all 4 sides and protrude by 3/4" from the face of the cabinet.



The door handle is mounted inside the door for shipping purposes. It must be removed and mounted to the outside surface of the door. Slots are provided in the door skin to ensure proper alignment of the top edges of the handles on each door.

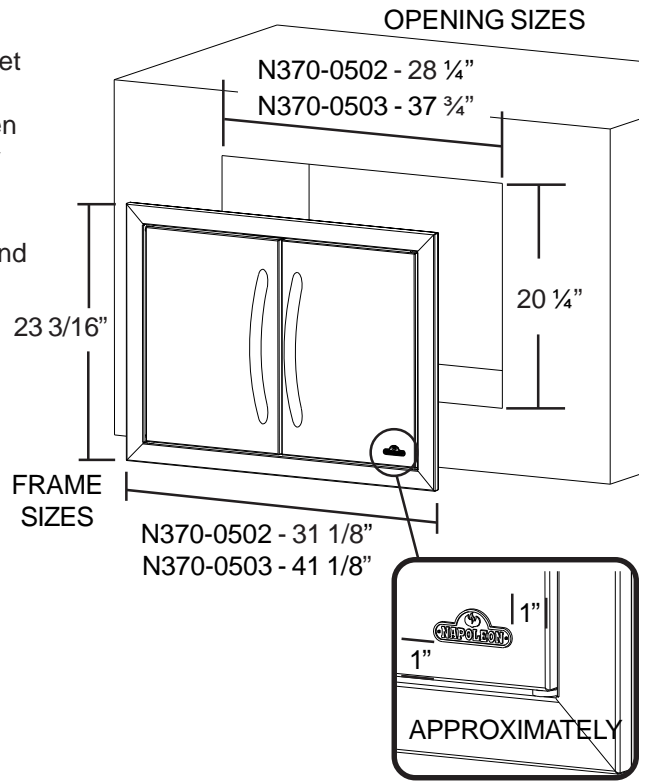

Ensure the bushings are mounted in the holes of the frame. Begin by sliding the pivot rod through the upper pivot hole in the door, then through the upper bushing and hole in the frame. Align the bottom pivot hole in the door over the bottom bushing and drop the pivot rod through until it rests on the crimped stop.

