

INSTALLER: LEAVE THIS MANUAL WITH THE APPLIANCE.
CONSUMER: RETAIN THIS MANUAL FOR FUTURE REFERENCE.
NEVER LEAVE CHILDREN OR OTHER AT RISK INDIVIDUALS ALONE WITH THE APPLIANCE.



INSTALLATION AND OPERATING INSTRUCTIONS

CERTIFIED UNDER AMERICAN NATIONAL STANDARDS, ANSI Z21.11.2, VOLUME II FOR UNVENTED ROOM HEATERS.

CVF42P
PROPANE

CVF42N
NATURAL GAS

UNVENTED MILLIVOLT
SYSTEM

CERTIFIED FOR THE UNITED STATES USING ANSI METHODS.

SAFETY INFORMATION

WARNING

If the information in these instructions are not followed exactly, a fire or explosion may result causing property damage, personal injury or loss of life.

- Do not store or use gasoline or other flammable vapors and liquids in the vicinity of this or any other appliance.
- **WHAT TO DO IF YOU SMELL GAS:**
 - Do not try to light any appliance.
 - Do not touch any electrical switch; do not use any phone in your building.
 - Immediately call your gas supplier from a neighbour's phone. Follow the gas supplier's instructions.
 - If you cannot reach your gas supplier, call the fire department.
- Installation and service must be performed by a qualified installer, service agency or the supplier.
- This is an unvented gas-fired heater that uses air (oxygen) from the room in which it is installed. Provisions for adequate combustion and ventilation air must be provided. Refer to section "COMBUSTION AND VENTILATION AIR PROVISIONS".

This appliance may be installed in an aftermarket, permanently located, manufactured (mobile) home, where not prohibited by local codes. This appliance is only for use with the type of gas indicated on the rating plate. This appliance is not convertible for use with other gases.



WARNING

HOT GLASS WILL CAUSE BURNS.

DO NOT TOUCH GLASS UNTIL COOLED.

NEVER ALLOW CHILDREN TO TOUCH GLASS.



APPLY SERIAL NUMBER LABEL FROM CARTON



Wolf Steel Ltd., 24 Napoleon Rd., Barrie, ON, L4M 0G8 Canada /
103 Miller Drive, Crittenden, Kentucky, USA, 41030

Phone (705)721-1212 • Fax (705)722-6031 • www.napoleonfireplaces.com • ask@napoleonproducts.com

TABLE OF CONTENTS

1.0	INSTALLATION OVERVIEW	3
2.0	INTRODUCTION	4
2.1	DIMENSIONS	5
2.2	GENERAL INSTRUCTIONS	5
2.3	GENERAL INFORMATION	7
2.4	RATING PLATE INFORMATION	8
3.0	INSTALLATION	9
3.1	COMBUSTION AND VENTILATION AIR PROVISIONS	9
3.2	DETERMINING CONFINED OR UNCONFINED SPACE	9
3.3	GAS INSTALLATION	11
3.4	OPTIONAL WALL SWITCH / THERMOSTAT	11
3.5	MOBILE HOME	11
4.0	FRAMING	12
4.1	MINIMUM CLEARANCE TO COMBUSTIBLES	13
4.2	MINIMUM MANTEL CLEARANCES	13
4.3	ALCOVE INSTALLATION	14
4.4	NAILING TAB INSTALLATION	14
5.0	FINISHING	15
5.1	GRATE INSTALLATION	15
5.2	LOG PLACEMENT	15
5.3	GLOWING EMBERS	17
5.4	CHARCOAL EMBERS	17
5.5	VERMICULITE	17
5.6	CHARCOAL LUMPS	17
5.7	HOOD	17
5.8	L42 LOUVRE INSTALLATION	18
5.9	LOGO PLACEMENT	18
6.0	OPTIONAL BLOWER INSTALLATION	19
7.0	OPERATION	21
8.0	ADJUSTMENT	22
8.1	VENTURI ADJUSTMENT	22
8.2	FLAME CHARACTERISTICS	22
9.0	MAINTENANCE	23
9.1	OXYGEN DEPLETION SENSOR PILOT CLEANING	23
9.2	CARE OF PLATED PARTS	24
10.0	REPLACEMENTS	24
11.0	TROUBLE SHOOTING GUIDE	26
12.0	WARRANTY	29
13.0	SERVICE HISTORY	30
14.0	NOTES	31

NOTE: Changes, other than editorial, are denoted by a vertical line in the margin

1.0 INSTALLATION OVERVIEW

Louvres, see "L42 LOUVRE INSTALLATION" section.

Hood, see "HOOD" section.

Rating Plate, see "RATING PLATE INFORMATION" section.

Logo, see "LOGO PLACEMENT" section.

Logs, see "LOG PLACEMENT" section.

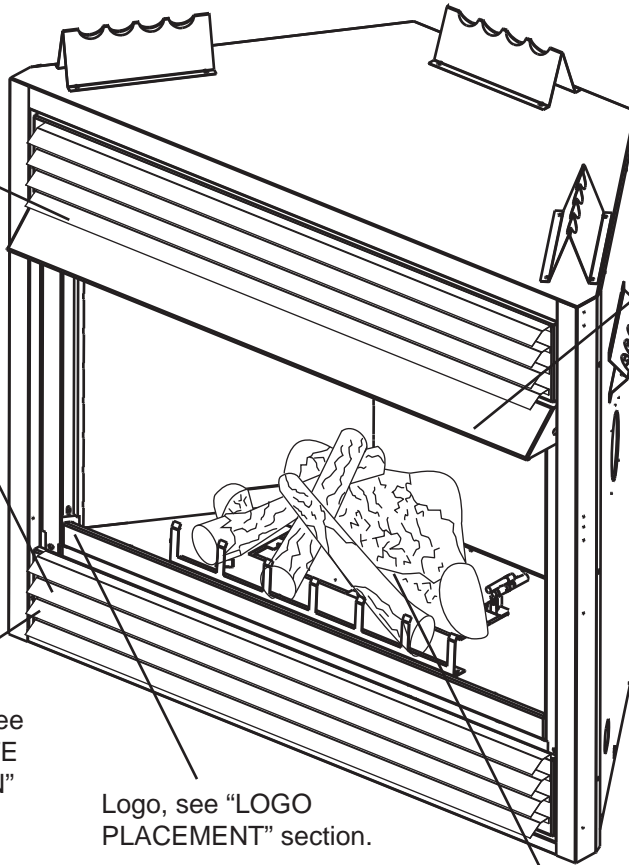

2.0 INTRODUCTION

WARNING

- **THIS APPLIANCE IS HOT WHEN OPERATED AND CAN CAUSE SEVERE BURNS IF CONTACTED.**
- **ANY CHANGES TO THIS APPLIANCE OR ITS CONTROLS CAN BE DANGEROUS AND IS PROHIBITED.**
- Under no circumstances should this appliance be modified.
- Do not operate appliance before reading and understanding operating instructions. Failure to operate appliance according to operating instructions could cause fire or injury.
- Risk of burns. The appliance should be turned off and cooled before servicing.
- Do not install damaged, incomplete or substitute components.
- Risk of cuts and abrasions. Wear protective gloves and safety glasses during installation. Sheet metal edges may be sharp.
- Provide adequate ventilation and combustion air. Provide adequate accessibility clearance for servicing and operating the appliance. Never obstruct the front opening of the appliance.
- If the appliance shuts off, do not re-light until you provide fresh air. If appliance keeps shutting off, have it serviced. Keep burner and control compartment clean.
- Do not burn wood or other materials in this appliance.
- Children and adults should be alerted to the hazards of high surface temperature and should stay away to avoid burns or clothing ignition.
- Young children should be carefully supervised when they are in the same room as the appliance. Toddlers, young children and others may be susceptible to accidental contact burns. A physical barrier is recommended if there are at risk individuals in the house. To restrict access to an appliance, install an adjustable safety gate to keep toddlers, young children and other at risk individuals out of the room and away from hot surfaces.
- Due to high temperatures, the appliance should be located out of traffic and away from furniture and draperies.
- Ensure you have incorporated adequate safety measures to protect infants/toddlers from touching hot surfaces.
- Clothing or other flammable material should not be placed on or near the appliance.
- Check with your local hearth specialty dealer for safety screens and hearth guards to protect children from hot surfaces. These screens and guards must be fastened to the floor.
- Any safety screen or guard removed for servicing must be replaced prior to operating the appliance.
- It is imperative that the control compartments, burners and circulating blower and its passageway in the appliance are kept clean. The appliance should be inspected before use and at least annually by a qualified service person. More frequent cleaning may be required due to excessive lint from carpeting, bedding material, etc. The appliance area must be kept clear and free from combustible materials, gasoline and other flammable vapours and liquids.
- Furniture or other objects must be kept a minimum of 4 feet away from the front of the appliance.
- Do not use this appliance if any part has been under water. Immediately call a qualified service technician to inspect the appliance and to replace any part of the control system and any gas control which has been under water.
- Do not allow fans to blow directly into the appliance. Avoid any drafts that alter burner flame patterns.
- Do not use a blower insert, heat exchanger insert or other accessory not approved for use with this appliance.
- Carbon or soot should not occur in a vent free appliance as it can distribute into the living area of your home. If you notice any signs of carbon or soot, immediately turn off your appliance and arrange to have it serviced by a qualified technician before operating it again.
- Keep the packaging material out of reach of children and dispose of the material in a safe manner. As with all plastic bags, these are not toys and should be kept away from children and infants.
- As with any combustion appliance, we recommend having your appliance regularly inspected and serviced as well as having a Carbon Monoxide Detector installed in the same area to defend you and your family against Carbon Monoxide.
- If equipped, the screen must be in place (closed) when the appliance is in operation.
- Ensure clearances to combustibles are maintained when building a mantel or shelves above the appliance. Elevated temperatures on the wall or in the air above the appliance can cause melting, discolouration or damage to decorations, a T.V. or other electronic components.

3.4B

2.1 DIMENSIONS

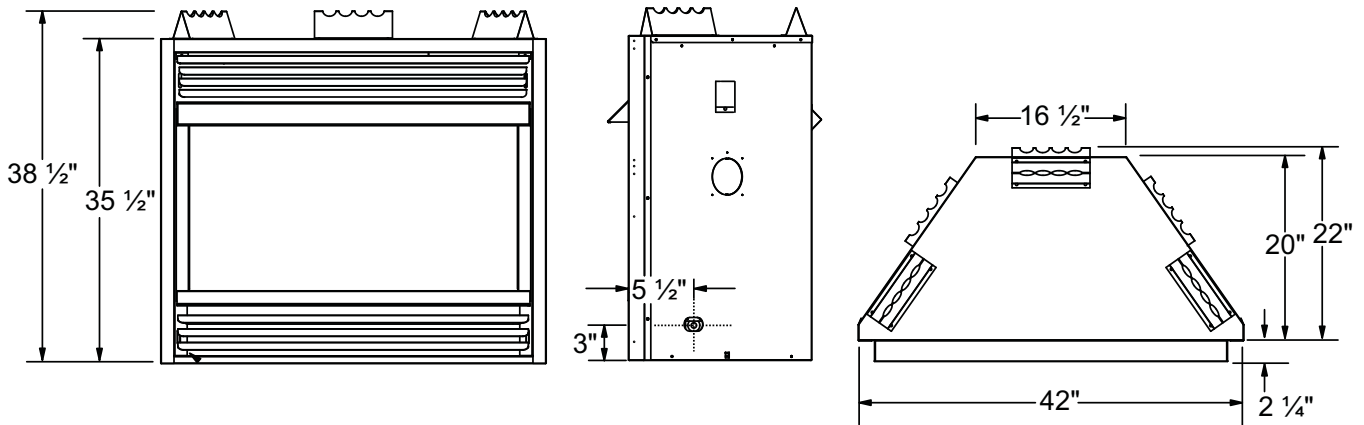

2.2 GENERAL INSTRUCTIONS

! WARNING	
<p>* CARBON MONOXIDE POISONING MAY LEAD TO DEATH EARLY SIGNS OF CARBON MONOXIDE POISONING RESEMBLE THE FLU, WITH HEADACHE, DIZZINESS AND/OR NAUSEA. IF YOU HAVE THESE SIGNS, THE HEATER MAY NOT BE WORKING PROPERLY. GET FRESH AIR AT ONCE! HAVE HEATER SERVICED. SOME PEOPLE---PREGNANT WOMEN, PERSONS WITH HEART OR LUNG DISEASE, ANEMIA, THOSE UNDER THE INFLUENCE OF ALCOHOL, THOSE AT HIGH ALTITUDES--- ARE MORE AFFECTED BY CARBON MONOXIDE THAN OTHERS.</p>	
<p>IT IS RECOMMENDED THAT PERSONS WITH RESPIRATORY PROBLEMS NOT USE VENT FREE APPLIANCES</p>	
<p>THE APPLIANCE IS ONLY FOR USE WITH THE TYPE OF GAS INDICATED ON THE RATING PLATE. THIS APPLIANCE IS NOT CONVERTIBLE FOR USE WITH OTHER GASES.</p>	
<p>OBJECTS PLACED IN FRONT OF THE HEATER SHOULD BE KEPT A MINIMUM OF 48" AWAY FROM THE FRONT FACE OF THE APPLIANCE.</p>	
<p>USE ONLY WOLF STEEL APPROVED OPTIONAL ACCESSORIES AND REPLACEMENT PARTS WITH THIS APPLIANCE. USING NON-LISTED ACCESSORIES AND REPLACEMENT PARTS (BLOWERS, LOUVRES, TRIMS, GAS COMPONENTS, VENT COMPONENTS, ETC.) COULD RESULT IN A SAFETY HAZARD AND WILL VOID THE LIMITED LIFETIME WARRANTY.</p>	
<p>NOT DESIGNED FOR USE WITH A GLASS DOOR. SCREEN MUST BE CLOSED WHEN APPLIANCE IS IN OPERATION.</p>	
<p>THIS APPLIANCE MUST NOT BE INSTALLED IN A BEDROOM OR BATHROOM.</p>	

This gas appliance should be installed and serviced by a qualified installer to conform with local codes. Installation practices vary from region to region and it is important to know the specifics that apply to your area, for example: in Massachusetts State:

- The appliance off valve must be a "T" handle gas cock.
- The flexible connector must not be longer than 36".
- The appliance is not approved for installation in a bedroom or bathroom unless the appliance is a direct vent sealed combustion product.
- A carbon monoxide detector is required in all rooms containing gas fired appliances.
- **WARNING:** This product must be installed by a licensed plumber or gas fitter when installed within the commonwealth of Massachusetts.
- Un-vented room appliance shall be installed in accordance with 527 CMR 30.00 and 248 CMR 3.00 through 7.00.
- Sellers of un-vented propane or natural gas-fired space / room appliances shall provide to each purchaser a copy of 527 CMR 30.00 upon the sale of the appliance from http://www.napoleonfireplaces.com/Webshare/installation_manuals/mass_requirements.pdf

In absence of local codes, install the appliance to the current National Fuel Gas Code, ANSI Z223.1 Installation Code which can be obtained from:

American National Standards Institute Inc.
1430 Broadway
New York, NY 10018

or

National Fire Protection Association Inc.
Batterymarch Park
Quincy, MA 02269

The appliance and its individual shutoff valve must be disconnected from the gas supply piping system during any pressure testing of that system at test pressures in excess of 1/2 psig (3.5 kPa). The appliance must be isolated from the gas supply piping system by closing its individual manual shutoff valve during any pressure testing of the gas supply piping system at test pressures equal to or less than 1/2 psig (3.5 kPa). When installed with a blower the junction box must be electrically connected and grounded in accordance with local codes. In the absence of local codes, use the current ANSI / NFPA 70 National Electric Code. In the case where the blower is equipped with a power cord it must be connected into a properly grounded receptacle. The grounding prong must not be removed from the cord plug.

As long as the required clearance to combustibles is maintained, the most desirable and beneficial location for the appliance is in the center of a building, thereby allowing the most efficient use of the heat created. The location of windows, doors and the traffic flow in the room where the appliance is to be located should be considered.



If the appliance is installed directly on carpeting, vinyl tile or other combustible material other than wood flooring, the appliance shall be installed on a metal or wood panel extending the full width and depth. **NOTE: This does not apply to stoves.**

* Air shortage caused by an inadequate air supply, improper log positions, the addition of foreign or unapproved materials or the failure to properly maintain the appliance, may result in incomplete combustion of the fuel. Incomplete combustion results in soot being deposited inside the firebox as well as surfaces outside the appliance. If any soot deposits are observed, shut off the appliance immediately and arrange for it to be serviced by a qualified technician.

4.2D

2.3 GENERAL INFORMATION

For your satisfaction, this appliance has been test-fired to assure its operation and quality!

CVF42		
	NG	LP
Altitude (FT)	2,000*	2,000*
Max. Input (BTU/HR)	30,000	30,000
Min. Inlet Gas Supply Pressure	4.5" Water Column	11" Water Column
Max. Inlet Gas Supply Pressure	7" Water Column	13" Water Column
Manifold Pressure (Under Flow Conditions)	3.5" Water Column	10" Water Column

* When the appliance is installed at elevations above 2,000ft, and in the absence of specific recommendations from the local authority having jurisdiction, the certified high altitude input rating shall be reduced at the rate of 4% for each additional 1,000ft. Expansion / contraction noises during heating up and cooling down cycles are normal and to be expected.

No external electricity (110 volts or 24 volts) is required for the gas system operation. Expansion / contraction noises during heating up and cooling down cycles are normal and are to be expected.

This appliance is only for use with the type of gas indicated on the rating plate. This appliance is not convertible for use with other gases, unless a certified kit is used.

This appliance is equipped with a pilot light safety system referred to as an oxygen depletion sensor and is designed to turn off the appliance if not enough fresh air is available.

Use only accessories designed for and listed with your specific appliance.

2.4 RATING PLATE INFORMATION

CERTIFIED UNDER: ANSI Z21.11.2a-2008 VOLUME II, UNVENTED ROOM HEATER

THIS APPLIANCE MAY BE INSTALLED IN AN AFTERMARKET, PERMANENTLY LOCATED, MANUFACTURED (MOBILE) HOME, WHERE NOT PROHIBITED BY LOCAL CODES. THIS APPLIANCE IS ONLY FOR USE WITH THE TYPE OF GAS INDICATED ON THE RATING PLATE. THIS APPLIANCE IS NOT CONVERTIBLE FOR USE WITH OTHER GASES.



Intertek

THIS IS A GAS-FIRED UNVENTED ROOM HEATER THAT REQUIRES ADEQUATE COMBUSTION AND VENTILATION AIR. THIS UNIT IS NOT APPROVED FOR BEDROOM, BATHROOM AND BED-SITTING ROOM INSTALLATION.

9700539 (WSL)

4001658 (NAC)

GVF42-N / CVF42-N

**0-2000FT (0-610m)

30,000 BTU/h

22,000 BTU/h

MANIFOLD PRESSURE: 3.5" WATER COLUMN

MINIMUM SUPPLY PRESSURE: 4.5" WATER COLUMN

MAXIMUM SUPPLY PRESSURE: 7.0" WATER COLUMN

SIT CONTROL: #820637

OPERATING PILOT OXYPROTECTOR: #8214

MODEL

ALTITUDE

INPUT

REDUCED INPUT

4001657 (NGZ)

4001659 (WJUSA)

GVF42-P / CVF42-P

0-2000FT (0-610m)**

30,000 BTU/h

22,000 BTU/h

MANIFOLD PRESSURE: 10" WATER COLUMN

MINIMUM SUPPLY PRESSURE: 11" WATER COLUMN

MAXIMUM SUPPLY PRESSURE: 13" WATER COLUMN

SIT CONTROL: #820636

OPERATING PILOT OXYPROTECTOR: #8404

** ABOVE 2,000FT, CONSULT LOCAL AUTHORITY HAVING JURISDICTION

NOT FOR USE WITH SOLID FUEL.

WARNING: FIREPLACE SCREENS MUST BE CLOSED WHILE IN OPERATION. DO NOT ADD ANY MATERIAL TO THE APPLIANCE, WHICH WILL COME IN CONTACT WITH THE FLAMES, OTHER THAN THAT SUPPLIED BY THE MANUFACTURER WITH THE APPLIANCE. DONOT USE BLOWER INSERT, HEAT EXCHANGER INSERT OR OTHER ACCESSORIES NOT APPROVED FOR USE WITH THIS HEATER. IMPROPER INSTALLATION, ADJUSTMENT, ALTERATION, SERVICE OR MAINTAINANCE CAN CAUSE PROPERTY DAMAGE, PERSONAL INJURY OR LOSS OF LIFE. REFER TO THE OWNER'S INFORMATION MANUAL PROVIDED WITH THIS APPLIANCE. INSTALLATION AND SERVICE MUST BE PERFORMED BY A QUALIFIED INSTALLER, SERVICE AGENCY OR THE GAS SUPPLIER.

MINIMUM CLEARANCE TO COMBUSTIBLE MATERIALS:

TOP / SIDES / BACK / FLOOR 0"

RECESSED DEPTH 22"

MANTEL 2"

WOLF STEEL LTD.

24 NAPOLEON ROAD, BARRIE, ON, L4M 0G8 CANADA

MAXIMUM HORIZONTAL EXTENSION: 2". SEE INSTRUCTION MANUAL FOR GREATER EXTENSIONS.

ELECTRICAL RATING: 115V 0.82AMP, 60HZ

OPTIONAL FAN KIT: GZ550-KT

SERIAL NUMBER: G/CVF42

W385-0248 / G

This illustration is for reference only. Refer to the rating plate on the appliance for accurate information.

INSTALLER: It is your responsibility to check off the appropriate box on the rating plate according to the model, venting and gas type of the appliance.

For rating plate location, see "INSTALLATION OVERVIEW" section.

NOTE: The rating plate must remain with the appliance at all times. It must not be removed.

3.0 INSTALLATION

3.1 COMBUSTION AND VENTILATION AIR PROVISIONS

This appliance shall not be installed in a confined space or unusually tight construction unless provisions are provided for adequate combustion and ventilation air.

The National Fuel Gas Code, ANSI Z223.1 / NFPA 54 defines a confined space as a space whose volume is less than 50 cubic feet per 1,000 Btu per hour (4.8 m³ per kw) of the aggregate input rating of all appliances installed in that space and an unconfined space as a space whose volume is not less than 50 cubic feet per 1,000 Btu per hour (4.8 m³ per kw) of the aggregate input rating of all appliances installed in that space. Rooms communicating directly with the space in which the appliances are installed, through openings not furnished with doors are considered a part of the unconfined space.

17.1A

The CVF42 is rated at 30,000 BTUs per hour for natural gas and 30,000 BTUs for propane and therefore requires a minimum unconfined space of 1,500 cubic feet.

3.2 DETERMINING CONFINED OR UNCONFINED SPACE

To determine the volume of the room where the appliance is to be installed, multiply the width x the length x the ceiling height of that room measured in feet. If any adjoining rooms are connected by grilles or openings such as kitchen pass-throughs, etc., the volume of those rooms may be added to the total.

Multiply the room volume by 1000 and divide this amount by 50 to determine the maximum BTU/hr that the space can support with adequate combustion and ventilation air.

Add the Btu/hr of all fuel burning appliances located within the space such as gas furnace, gas water appliance, etc. Do not include direct vent gas appliances which draw their input and output air from and to the outdoors.

WARNING

IF THE AREA IN WHICH THE APPLIANCE MAY BE OPERATED IS SMALLER THAN THAT DEFINED AS AN UNCONFINED SPACE OR IF THE BUILDING IS OF UNUSUALLY TIGHT CONSTRUCTION, PROVIDE ADEQUATE COMBUSTION AND VENTILATION AIR BY ONE OF THE METHODS DESCRIBED IN THE NATIONAL FUEL GAS CODE ANSI Z223.1/ NFPA 54 , AIR FOR COMBUSTION AND VENTILATION, OR THE APPLICABLE LOCAL CODE.

IF THE AREA IN WHICH THE APPLIANCE MAY BE OPERATED DOES NOT MEET THE REQUIRED VOLUME FOR INDOOR COMBUSTION AIR, COMBUSTION AND VENTILATION AIR SHALL BE PROVIDED BY ONE OF THE METHODS DESCRIBED IN THE ANSI Z223.1 / NFPA 54, THE INTERNATIONAL FUEL GAS CODE, OR APPLICABLE LOCAL CODES.

Unusually tight construction is defined as construction where:

- A) Walls and ceilings exposed to the outside atmosphere have a continuous water vapour retarder with a rating of 1 perm (6 x 10⁻¹¹ kg per pa-sec-m²) or less with openings gasketed or sealed, and
- B) Weather stripping has been added on openable windows and doors, and
- C) Caulking or sealants are applied to areas such as joints around window and door frames, between sole plates and floors, between wall-ceiling joints, between wall panels, at penetrations for plumbing, electrical, and gas lines, and at other openings.

An unvented room appliance is recommended for use as a secondary heat source rather than as a primary source. Gas combustion produces water vapour which could occur at the rate of approximately one ounce of water for every 1,000 BTU/hr of gas input. During the cold weather season, indoor humidity levels tend to be low. Consequently, this water vapour can enhance the living space. However if a problem should occur:

- A) Ensure sufficient combustion and circulation air
- B) Use a dehumidifier
- C) Do not use the unvented room appliance as a primary heat source

Without sufficient fresh air for proper operation, poor fuel combustion can result. Carbon Monoxide is a result of poor combustion.

If additional fresh air is required, use one of the methods described in the National Fuel Gas Code, ANSI Z223.1 / NFPA54 or the applicable local code.

Room Volume = Length x Width x Height
 Max BTU/hr = Room Volume x 1000 / 50

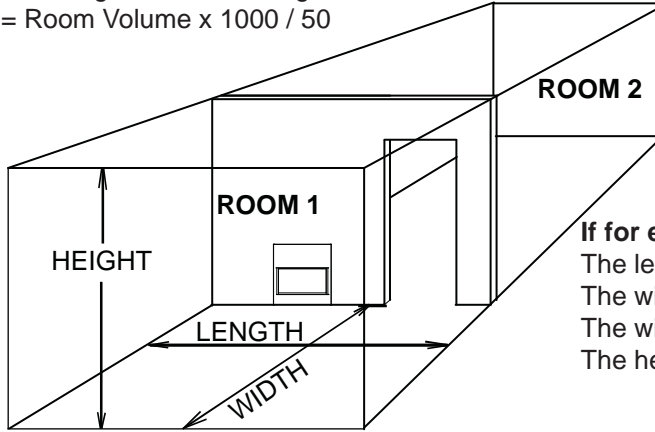

If for example:
 The length of the rooms is 10 feet,
 The width of Room 1 is 10 feet,
 The width of Room 2 is 15 feet,
 The height of the rooms is 8 feet.

The volume of Room 1: 10x10x8 = 800 cubic feet
 The volume of Room 2: 10x15x8 = 1200 cubic feet

19.1B

EXAMPLE 1:

In this example, because there is no door to the adjoining room, the volume of the adjoining room may be added to the volume of the room with the heater to get a total unconfined space.

The total unconfined space: 800 + 1200 = 2000 cubic feet.

Maximum BTU/h: $\frac{2000 \times 1000}{50} = 40,000$ BTU/h

19.2

If there are no more fuel burning appliances within this space then the 30,000 BTU/h input of the appliance is suitable to be installed. This also assumes that the construction of this space is not unusually tight.

EXAMPLE 2:

If in this example a solid door separates Room 1 from Room 2, the volume of Room 2 could not be used. In this case the maximum BTU/h would be:

Maximum BTU/h: $\frac{800 \times 1000}{50} = 16,000$ BTU/h

19.3

This would be considered a confined space since it can not support the 30,000 BTU/h input of the appliance and it would be necessary to provide adequate combustion and ventilation air to Room 1.

3.3 GAS INSTALLATION

! WARNING
RISK OF FIRE, EXPLOSION OR ASPHYXIATION. ENSURE THERE ARE NO IGNITION SOURCES SUCH AS SPARKS OR OPEN FLAMES.
SUPPORT GAS CONTROL WHEN ATTACHING GAS SUPPLY PIPE TO PREVENT DAMAGING GAS LINE.
ALWAYS LIGHT THE PILOT WHETHER FOR THE FIRST TIME OR IF THE GAS SUPPLY HAS RUN OUT WITH THE GLASS DOOR OPENED OR REMOVED. PURGING OF THE GAS SUPPLY LINE SHOULD BE PERFORMED BY A QUALIFIED SERVICE TECHNICIAN. ASSURE THAT A CONTINUOUS GAS FLOW IS AT THE BURNER BEFORE CLOSING THE DOOR. ENSURE ADEQUATE VENTILATION. FOR GAS AND ELECTRICAL LOCATIONS, SEE "DIMENSION" SECTION.
ALL GAS CONNECTIONS MUST BE CONTAINED WITHIN THE APPLIANCE WHEN COMPLETE.
HIGH PRESSURE WILL DAMAGE VALVE. DISCONNECT GAS SUPPLY PIPING BEFORE TESTING GAS LINE AT TEST PRESSURES ABOVE 1/2 PSIG.
VALVE SETTINGS HAVE BEEN FACTORY SET, DO NOT CHANGE.

Installation and servicing to be done by a qualified installer.

- A. Move the appliance into position and secure.
- B. If equipped with a flex connector the appliance is designed to accept a 1/2" gas supply. Without the connector it is designed to accept a 3/8" gas supply. The appliance is equipped with a manual shut off valve to turn off the gas supply to the appliance.
- C. Connect the gas supply in accordance to local codes. In the absence of local codes, install to the current CAN/CSA-B149.1 Installation Code in Canada or to the current National Fuel Gas Code, ANSI Z223.1 / NFPA 54 in the United States.
- D. When flexing any gas line, support the gas valve so that the lines are not bent or kinked.
- E. The gas line flex-connector should be installed to provide sufficient movement for shifting the burner assembly on it's side to aid with servicing components.
- F. Check for gas leaks by brushing on a soap and water solution. **Do not use open flame.**

30.1A

3.4 OPTIONAL WALL SWITCH / THERMOSTAT

! WARNING
DO NOT CONNECT EITHER THE WALL SWITCH, THERMOSTAT OR GAS VALVE DIRECTLY TO 110 VOLT ELECTRICITY.

For ease of accessibility, an optional remote wall switch or millivolt thermostat may be installed in a convenient location. Route a 2 strand, solid core millivolt wire from the valve to the wall switch or millivolt thermostat. The recommended maximum lead length depends on wire size:

WIRE SIZE	MAX. LENGTH
14 gauge	100 feet
16 gauge	60 feet
18 gauge	40 feet

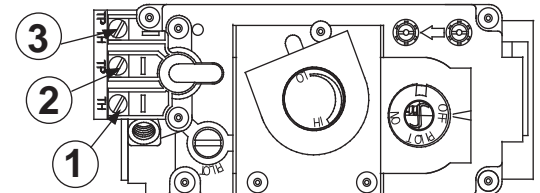

Disconnect the existing wires from terminals 1 and 3 (from the ON/OFF switch) and replace with the leads from the wall switch / millivolt thermostat.

50.1

3.5 MOBILE HOME

Suitable for mobile home installation where the mobile home has been permanently placed on its site. This appliance must not be installed in a bedroom or bathroom.

This appliance may be installed in an aftermarket permanently located, manufactured (mobile) home, where not prohibited by local codes.

4.0 FRAMING

! WARNING**RISK OF FIRE!**

IN ORDER TO AVOID THE POSSIBILITY OF EXPOSED INSULATION OR VAPOUR BARRIER COMING IN CONTACT WITH THE APPLIANCE BODY, IT IS RECOMMENDED THAT THE WALLS OF THE APPLIANCE ENCLOSURE BE "FINISHED" (IE: DRYWALL / SHEETROCK), AS YOU WOULD FINISH ANY OTHER OUTSIDE WALL OF A HOME. THIS WILL ENSURE THAT CLEARANCE TO COMBUSTIBLES IS MAINTAINED WITHIN THE CAVITY.

DO NOT NOTCH THE FRAMING AROUND THE APPLIANCE STAND-OFFS. FAILURE TO MAINTAIN AIR SPACE CLEARANCE MAY CAUSE OVER HEATING AND FIRE. PREVENT CONTACT WITH SAGGING OR LOOSE INSULATION OR FRAMING AND OTHER COMBUSTIBLE MATERIALS. BLOCK OPENING INTO THE CHASE TO PREVENT ENTRY OF BLOWN-IN INSULATION. MAKE SURE INSULATION AND OTHER MATERIALS ARE SECURED.

WHEN CONSTRUCTING THE ENCLOSURE ALLOW FOR FINISHING MATERIAL THICKNESS TO MAINTAIN CLEARANCES. FRAMING OR FINISHING MATERIAL CLOSER THAN THE MINIMUMS LISTED MUST BE CONSTRUCTED ENTIRELY OF NON-COMBUSTIBLE MATERIALS. MATERIALS CONSISTING ENTIRELY OF STEEL, IRON, BRICK, TILE, CONCRETE, SLATE, GLASS OR PLASTERS, OR ANY COMBINATION THEREOF ARE SUITABLE. MATERIALS THAT ARE REPORTED AS PASSING ASTM E 136, STANDARD TEST METHOD FOR BEHAVIOUR OF MATERIALS IN A VERTICAL TUBE FURNACE AT 750°C AND UL763 SHALL BE CONSIDERED NON-COMBUSTIBLE MATERIALS.

MINIMUM CLEARANCE TO COMBUSTIBLES MUST BE MAINTAINED OR A SERIOUS FIRE HAZARD COULD RESULT.

THE APPLIANCE REQUIRES A MINIMUM ENCLOSURE HEIGHT. MEASURE FROM THE APPLIANCE BASE.

IF STEEL STUD FRAMING KITS WITH CEMENT BOARD ARE PROVIDED, THEY MUST BE INSTALLED.

71.1

It is best to frame your appliance after it is positioned. Use 2x4's and frame to local building codes.

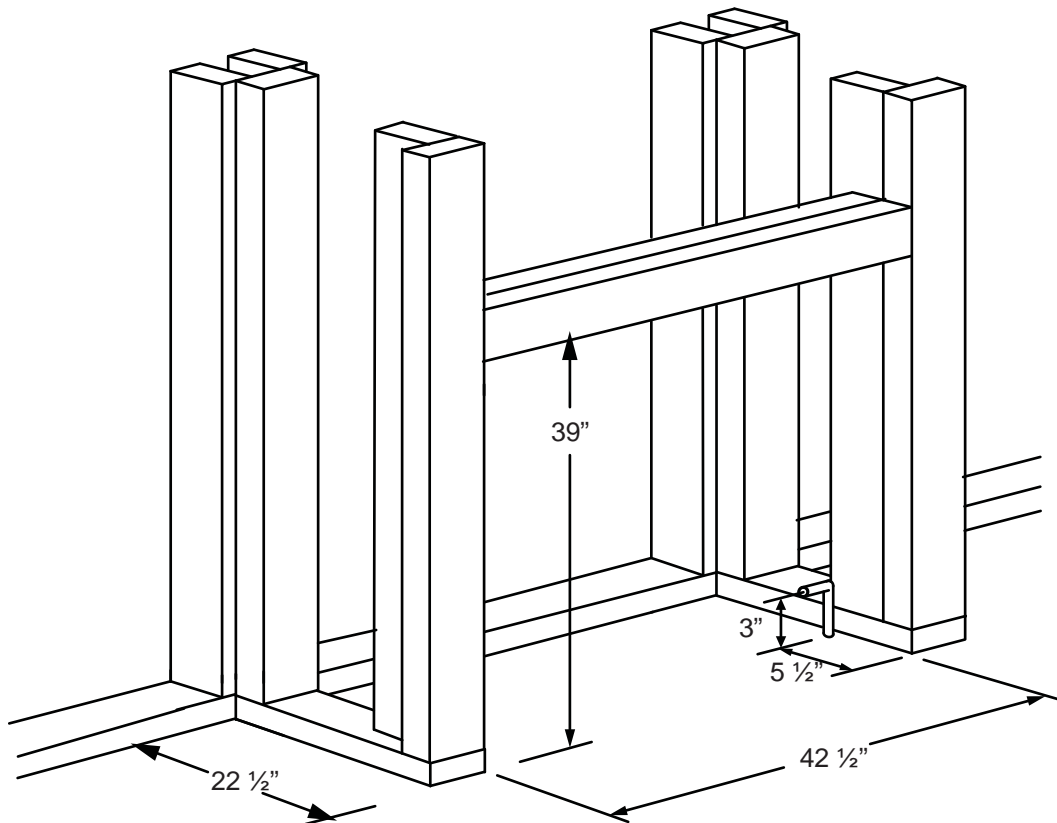

4.1 MINIMUM CLEARANCE TO COMBUSTIBLES

Minimum clearance to combustible construction from appliance:

sides, back, bottom and top of the unit	0 inch
recessed depth	22 inches

It is not necessary to install a hearth extension with this appliance.

When roughing in the appliance, raise the appliance to accommodate for the thickness of the finished floor materials, i.e. tile, carpeting, hard wood, which if not planned for will interfere with the opening of the lower access door and the installation of many decorative flashing accessories.

Raise the appliance up to the height of the finished flooring to ensure control access and accessory installations.

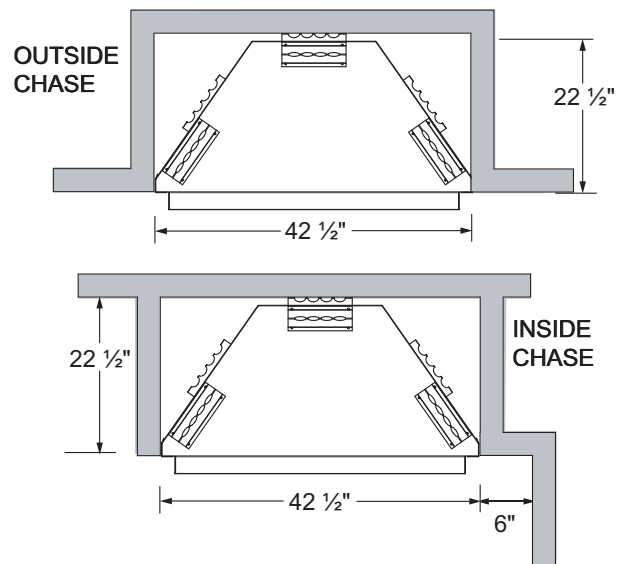
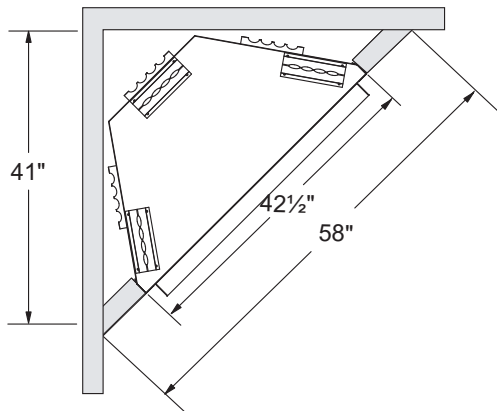

4.2 MINIMUM MANTEL CLEARANCES

! WARNING

RISK OF FIRE, MAINTAIN ALL SPECIFIED AIR SPACE CLEARANCES TO COMBUSTIBLES. FAILURE TO COMPLY WITH THESE INSTRUCTIONS MAY CAUSE A FIRE OR CAUSE THE APPLIANCE TO OVERHEAT. ENSURE ALL CLEARANCES (I.E. BACK, SIDE, TOP, VENT, MANTEL, FRONT, ETC.) ARE CLEARLY MAINTAINED.

WHEN USING PAINT OR LACQUER TO FINISH THE MANTEL, THE PAINT OR LACQUER MUST BE HEAT RESISTANT TO PREVENT DISCOLOURATION.

73.1

Combustible materials may be installed flush with the front of the appliance but must not cover any of the black face-areas of the appliance. Non-combustible material (brick, stone or ceramic tile) may protrude in these areas.

Combustible mantel clearance can vary according to the mantel depth. Use the graph to help evaluate the clearance needed.

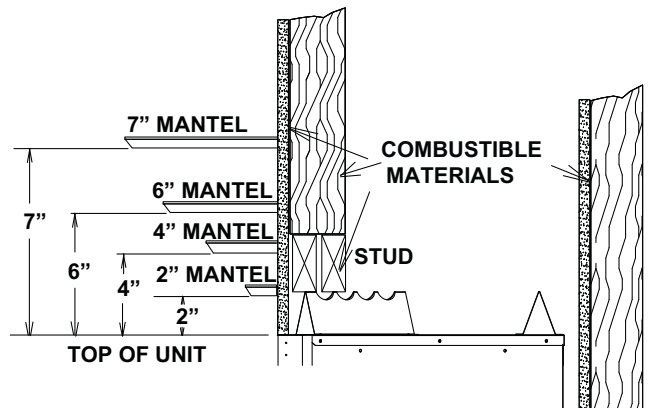
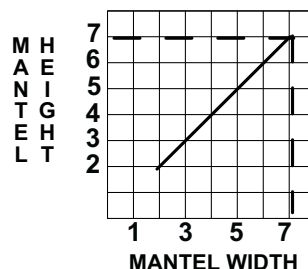

4.3 ALCOVE INSTALLATION

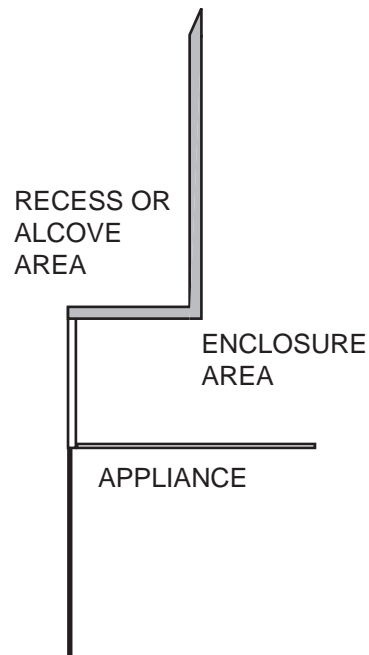

NOTE: Recesses or alcoves above the appliance can be made as deep as desired provided the minimum clearances to combustibles are maintained.

Non-combustible material can be used, provided the minimum clearances to combustible materials are applied. The minimum enclosure volume must be increased by no less than the volume of the recess. This adjustment can be made by increasing any or all of the height, width and depth of the enclosure.

71.2

4.4 NAILING TAB INSTALLATION

- A.** Attach the nailing tabs to the corner posts using the 2 sheet metal screws supplied. Secure through the centre of the top and bottom slots in the nailing tab and then through the existing holes in the corner posts. If there are no existing holes, follow these instructions:
- B.** To determine the final location of the nailing tab you must first determine the thickness of your finishing material (i.e. drywall). This will determine the dimension from the front edge of the corner post to the nailing tab. Once the nailing tab is in the desired location, drill through the centre hole of the nailing tab. Secure with a sheet metal screw*.

* Additional set screws may be installed.



55.1A

5.0 FINISHING

! WARNING
RISK OF FIRE!
NEVER OBSTRUCT THE FRONT OPENING OF THE APPLIANCE.
THE FRONT OF THE APPLIANCE MUST BE FINISHED WITH ANY NON-COMBUSTIBLE MATERIALS SUCH AS BRICK, MARBLE, GRANITE, ETC., PROVIDED THAT THESE MATERIALS DO NOT GO BELOW THE SPECIFIED DIMENSION AS ILLUSTRATED. AS AN ALTERNATIVE, YOU CAN FINISH THE APPLIANCE WITH DRYWALL, SEE ILLUSTRATIONS TO FOLLOW.
FACING AND/OR FINISHING MATERIAL MUST NEVER OVERHANG INTO THE APPLIANCE OPENING.

72.2

5.1 GRATE INSTALLATION

The grate for this appliance has been removed for shipping purposes.

The grate must be installed before the logs are installed.

Remove the packaging from the grate and install onto the two pins as illustrated.

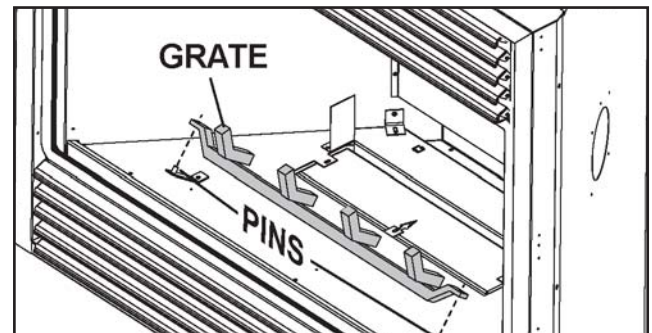

5.2 LOG PLACEMENT

! WARNING
LOGS MUST BE PLACED IN THEIR EXACT LOCATION IN THE APPLIANCE. DO NOT MODIFY THE PROPER LOG POSITIONS, SINCE APPLIANCE MAY NOT FUNCTION PROPERLY. DELAYED IGNITION AND CARBON / SOOT DISTRIBUTION THROUGHOUT THE LIVING AREA MAY OCCUR.
THE LOGS ARE FRAGILE AND SHOULD BE HANDLED WITH CARE.
DO NOT PLACE CHARCOAL EMBERS, VERMICULITE OR CHARCOAL LUMPS ON THIS BURNER.
ALL PREVIOUSLY APPLIED LOOSE MATERIAL (GLOWING EMBERS) MUST BE REMOVED PRIOR TO REAPPLICATION.
DO NOT CHANGE OR SUBSTITUTE THE GLOWING EMBER MATERIAL PROVIDED WITH THE APPLIANCE. IF REPLACING, USE ONLY REPLACEMENT GLOWING EMBERS AVAILABLE FROM YOUR LOCAL AUTHORIZED DEALER / DISTRIBUTOR.
FAILURE TO FOLLOW THESE INSTRUCTIONS WILL ADVERSELY EFFECT THE APPLIANCE'S PERFORMANCE AND MAY RESULT IN CARBON / SOOT DEPOSITS INSIDE THE APPLIANCE AND ON SURROUNDING SURFACES.

76.2B

PHAZER™ logs and glowing embers, exclusive to Continental Appliances, provide a unique and realistic glowing effect that is different in every installation. Take the time to carefully position the glowing embers for a maximum glowing effect. Log colours may vary. During the initial use of the appliance, the colours will become more uniform as colour pigments burn in during the heat activated curing process.

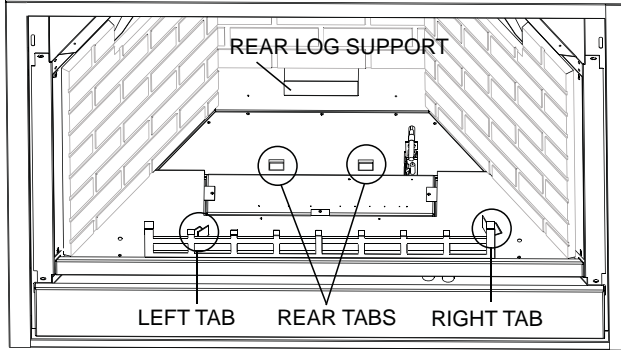

- A.** Prepare for log placement by ensuring the left, rear, and right tabs of the log support and firebox bottom are bent up to 90°, to aid in locating the logs.

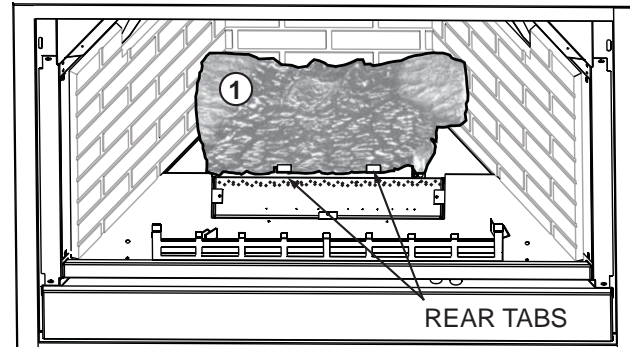

- B.** Place the back log ① onto the base of the firebox. Ensure that the back of the log rests against the rear log support on the back wall of the firebox, and behind the two rear tabs on the firebox bottom.

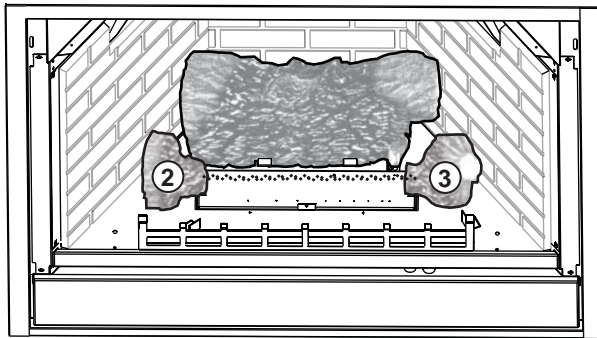

- C.** Move the two small logs ② & ③ into position, place holes in the bottom of the logs over the studs located on the burner.

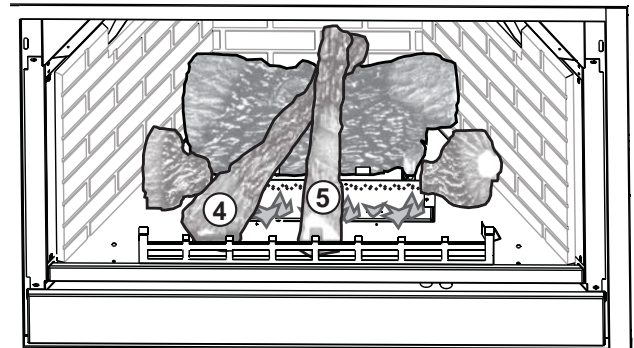

- D.** Place the bottom of the left crossover log ④ against the left tab of the log support and against the grate. Place the top of log ④ into the pocket provided on the back log ①. Position the notch located on the end of the center log ⑤ against the centre grate post with the other end of the log resting in the pocket of log ④.

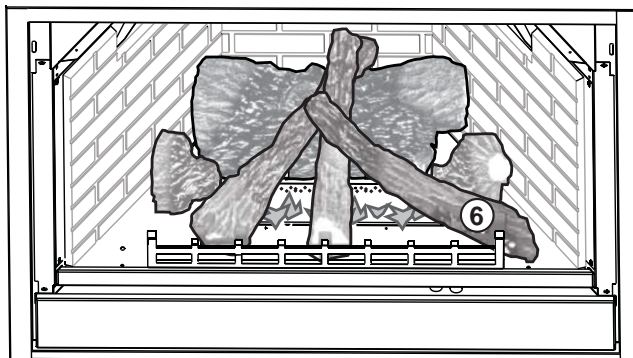

- E.** Place the bottom of the right crossover log ⑥ against the right tab of the log support and against the grate. Place the top into the pocket provided on log ⑤ and allow to rest against the bracket of the log support.

5.3 GLOWING EMBERS

Tear the glowing embers into pieces and place along the front row of ports covering all of the burner area in front of the small logs. Care should be taken to shred the embers into thin, small irregular pieces as only the exposed edges of the fibre hairs will glow. The ember material will only glow when exposed to direct flame; however, care should be taken to not block the burner ports. Blocked burner ports can cause an incorrect flame pattern, Carbon deposits and delayed ignition. Phazer™ logs glow when exposed to direct flame.



5.4 CHARCOAL EMBERS

Randomly place the charcoal embers along the front and sides of the log support tray in a realistic manner. **Fine dust found in the bottom of the bag should not be used.**

5.5 VERMICULITE

Sprinkle vermiculite around the charcoal embers.

NOTE: Vermiculite is not to be placed on the burner.

33.1

5.6 CHARCOAL LUMPS

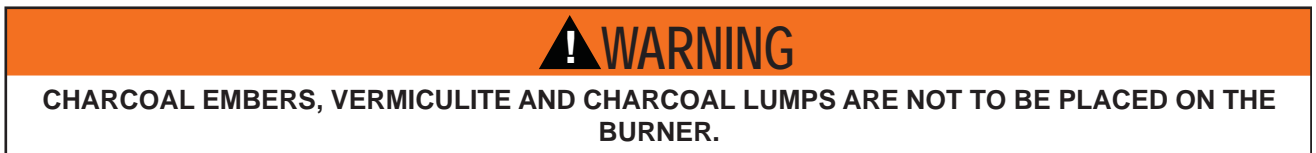

Place the lumps in front of the logs in a realistic manner taking care not to block any of the burner ports.

34.1

5.7 HOOD



- A. Remove the screws located on either side of the frame, above the curtain rod.

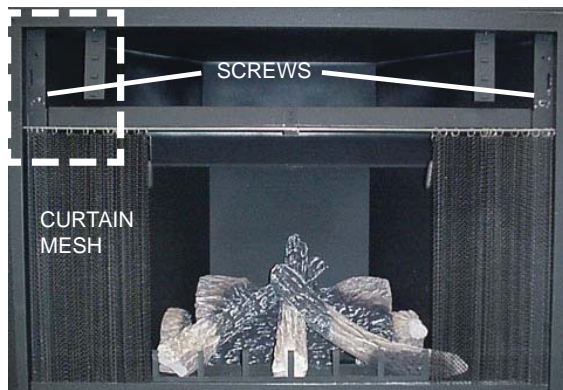

- B. Align the slots on the hood with the holes from which the screws were removed.



- C. Secure the hood using the screws removed in step 1. Ensure that the louvre brackets are positioned in front of the hood.

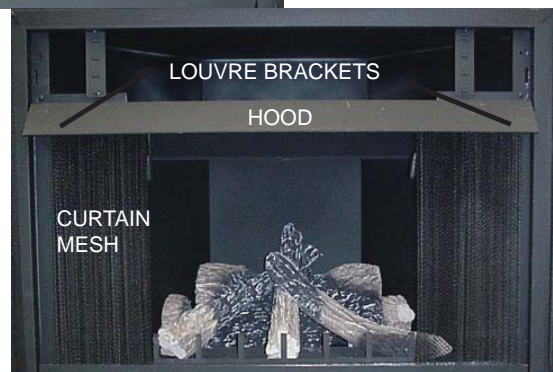

- D. The curtain mesh must be kept fully closed during operation to help prevent accidental burns from occurring.

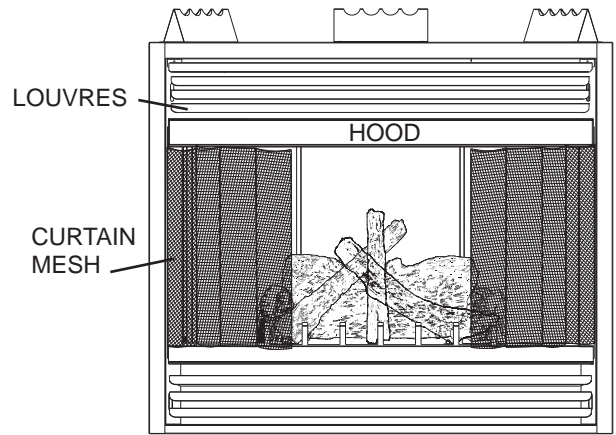

5.8 L42 LOUVRE INSTALLATION

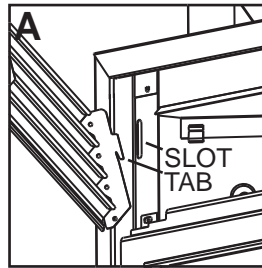
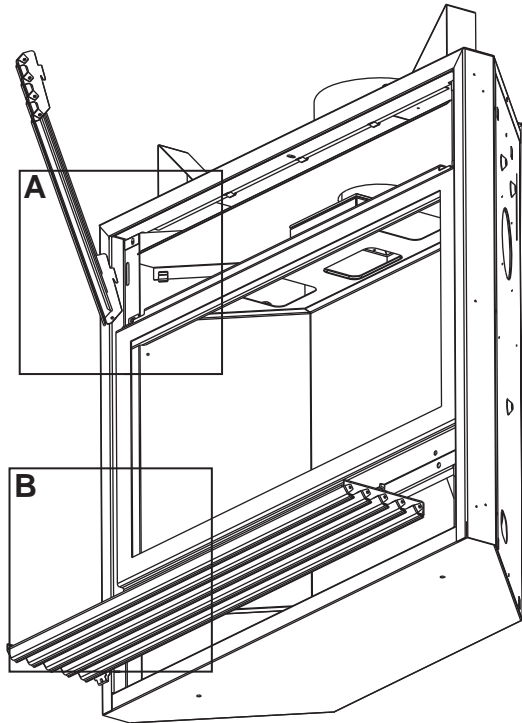

UPPER LOUVRES
Insert the louvre tabs into the slots located at the top left and right corners of the unit.

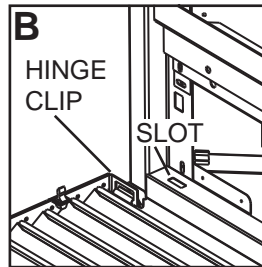

LOWER LOUVRES
Insert the hinge clips into the slots located at the bottom left and right corners of the unit.
To remove the louvres, pull the back tabs of the clips forward, while pushing the louvre assembly back. Lift the clip.

57.1A

5.9 LOGO PLACEMENT

Remove the backing of the logo supplied and place on the screen cover, as indicated.

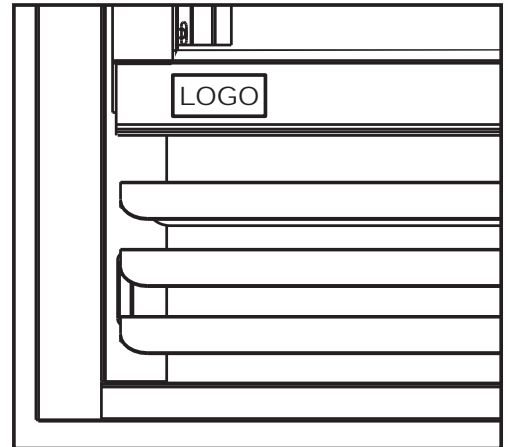

6.0 OPTIONAL BLOWER INSTALLATION

! WARNING
RISK OF FIRE AND ELECTRICAL SHOCK.
TURN OFF THE GAS AND ELECTRICAL POWER BEFORE SERVICING THIS APPLIANCE.
USE ONLY WOLF STEEL APPROVED OPTIONAL ACCESSORIES AND REPLACEMENT PARTS WITH THIS APPLIANCE. USING NON-LISTED ACCESSORIES (BLOWERS, DOORS, LOUVRES, TRIMS, GAS COMPONENTS, VENTING COMPONENTS, ETC.) COULD RESULT IN A SAFETY HAZARD AND WILL VOID THE WARRANTY AND CERTIFICATION.
ENSURE THAT THE FAN'S POWER CORD IS NOT IN CONTACT WITH ANY SURFACE OF THE APPLIANCE TO PREVENT ELECTRICAL SHOCK OR FIRE DAMAGE. DO NOT RUN THE POWER CORD BENEATH THE APPLIANCE.
THE WIRE HARNESS PROVIDED IN THE BLOWER KIT IS A UNIVERSAL HARNESS. WHEN INSTALLED, ENSURE THAT ANY EXCESS WIRE IS CONTAINED, PREVENTING IT FROM MAKING CONTACT WITH MOVING OR HOT OBJECTS.

51.5

INSTALLATION TO BE DONE BY A QUALIFIED INSTALLER and must be electrically connected and grounded in accordance with local codes. In the absence of local codes, use the current ANSI / NFPA 70 National Electrical Code.

If the appliance was not previously equipped with a blower:

Route a grounded 2-wire, 60hz power cable to the receptacle / junction box. At this point, it must be strain relieved and insulated.

The three slots on the blower mounting bracket allow ease of adjustment when attaching the blower. For a quiet running blower, do not allow the assembly to sit on the firebox base. Slide the vibration reducing pad (A) into the clip (C) and up against the threaded stud (B) at the other end. The blower must be able to be positioned entirely onto the pad.

To ease installation of the blower, remove the hinge screen and valve control door (lower louvres) from the base of the appliance.

Tilt the blower onto its side. Slide it past the controls and into the clip (C). Secure to the threaded stud using the lock washer and wing nut provided. Ensure that the blower does not touch the appliance base or the firebox.

Attach the connectors from the black and white wires to the thermal switch and secure the thermal switch bracket to the bottom left of the unit using the screws provided. Ensure that the thermal switch touches the firebox wall.

Attach the connectors from the black and red wires to the blower.

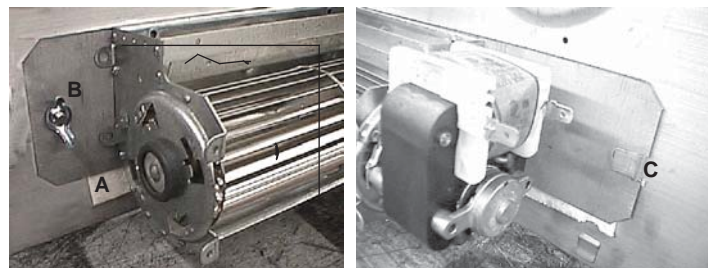
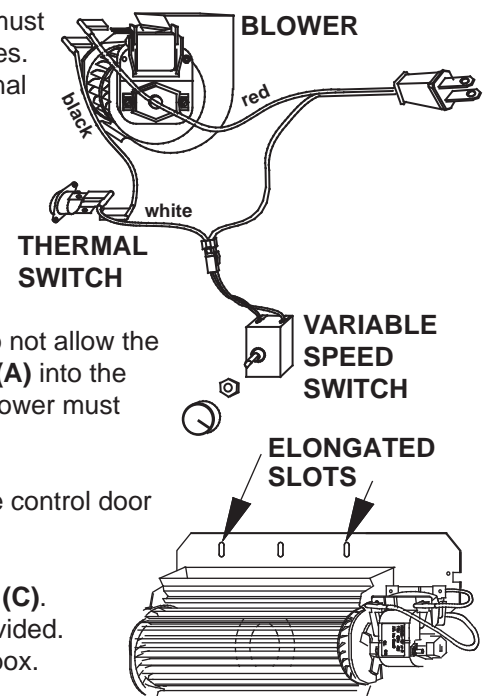

Attach and secure the variable speed switch using the nut provided. Plug the harness cord into the receptacle. The wire harness provided in this kit is a universal harness. When installed, ensure that any excess wire is contained, preventing it from making contact with moving or hot objects.

Because the blower is thermally activated, when turned on, it will automatically start approximately 10 minutes after lighting the

appliance and will run for approximately 30-45 minutes after the appliance has been turned off. Use of the fan increases the output of heat. Drywall dust will penetrate into the blower bearings, causing irreparable damage. Care must be taken to prevent drywall dust from coming into contact with the blower or its compartment. Any damage resulting from this condition is not covered by the warranty policy.

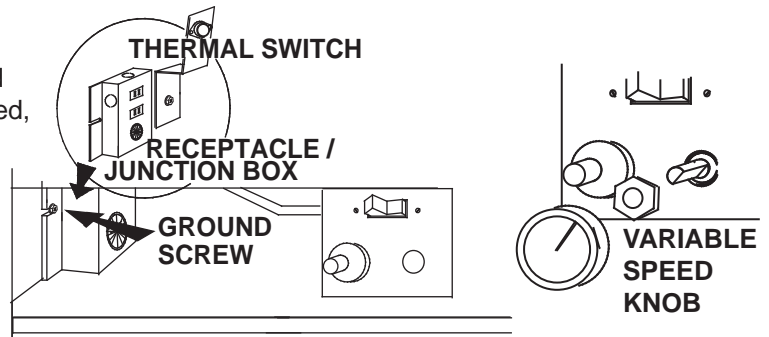

7.0 OPERATION

WARNING

IF YOU DO NOT FOLLOW THESE INSTRUCTIONS EXACTLY, A FIRE OR EXPLOSION MAY RESULT CAUSING PROPERTY DAMAGE, PERSONAL INJURY OR LOSS OF LIFE.

IF APPLICABLE ALWAYS LIGHT THE PILOT WHETHER FOR THE FIRST TIME OR IF THE GAS SUPPLY HAS RUN OUT WITH THE GLASS DOOR OPENED OR REMOVED.

If appliance shuts off, do not relight until you provide fresh air. If appliance keeps shutting off, have it serviced. Keep burner and control compartment clean.

When lit for the first time, the appliance will emit a slight odour for a few hours. This is a normal temporary condition caused by the curing of the logs and the “burn-in” of internal paints and lubricants used in the manufacturing process and will not occur again. After extended periods of non-operation such as following a vacation or a warm weather season, the appliance may emit a slight odour for a few hours. This is caused by dust particles burning off. In both cases, open a window to sufficiently ventilate the room.

FOR YOUR SAFETY READ BEFORE LIGHTING:

- This appliance is equipped with a pilot which must be lit by hand while following these instructions exactly.
- Before operating smell all around the appliance area for gas and next to the floor because some gas is heavier than air and will settle on the floor.
- Use only your hand to push in and turn the gas control knob. Never use tools. If the knob will not push in and turn by hand, do not try to repair it. Call a qualified service technician. Force or attempted repair may result in a fire or explosion.
- Do not use this appliance if any part has been under water. Immediately call a qualified service technician to inspect the appliance and replace any part of the control system and any gas control which has been under water.

WHAT TO DO IF YOU SMELL GAS:

- Do not try to light any appliance.
- Do not touch any electric switch; do not use any phone in your building.
- Immediately call your gas supplier from a neighbour’s phone. Follow the gas supplier’s instructions.
- If you cannot reach your gas supplier, call the fire department.

OXYGEN DEPLETION SENSOR

GAS KNOB

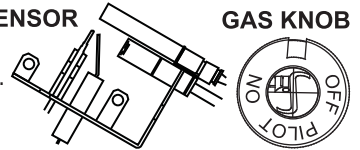

LIGHTING INSTRUCTIONS:

When lighting and re-lighting, the gas knob cannot be turned from pilot to off unless the knob is depressed.

- STOP! Read the above safety information on this label.
- Set the thermostat to lowest setting.
- Turn off all electric power to the appliance.
- Open the control door. Turn the gas knob clockwise to off.
- Wait five (5) minutes to clear out any gas. If you smell gas including near the floor, STOP! Follow “B” in the above safety information on this label. If you don’t smell gas go to the next step.
- Find pilot located in front of the back log.
- Turn gas knob counter-clockwise to pilot.
- Depress and hold gas knob while lighting the pilot with the push button ignitor. Keep knob fully depressed for one minute, then release. If pilot does not continue to burn repeat steps 3 through 7.
- With pilot lit, turn gas knob counter-clockwise to on. When the pilot has been turned off, ignition of the main burner may be delayed from 1-2 minutes. When the pilot has been left burning, ignition of the main burner should occur almost immediately.
- If equipped with remote on-off switch, main burner may not come on when you turn the valve to on. Remote switch must be in the on position to ignite burner.
- Turn on all electric power to the appliance.

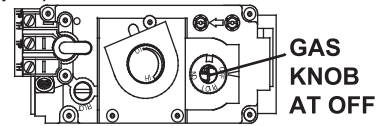

TO TURN OFF GAS

- Turn off all electric power to the appliance if service is to be performed.
- Push in gas control knob slightly and turn clockwise to off. Do not force.

47.1

8.0 ADJUSTMENT

8.1 VENTURI ADJUSTMENT

! WARNING

CARBON CAN BE DISTRIBUTED IN SURROUNDING LIVING AREA IF THE AIR SHUTTER IS IMPROPERLY ADJUSTED.

This appliance has an air shutter that has been factory set open according to the chart below:

Regardless of venturi orientation, closing the air shutter will cause a more yellow flame, but can lead to carboning. Opening the air shutter will cause a more blue flame, but can cause flame lifting from the burner ports. The flame may not appear yellow immediately; allow 15 to 30 minutes for the final flame colour to be established.

AIR SHUTTER ADJUSTMENT MUST ONLY BE DONE BY A QUALIFIED INSTALLER!

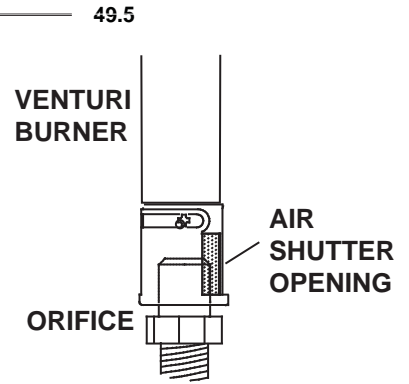

AIR SHUTTER OPENINGS	
NG	3/16"
LP	7/16"



8.2 FLAME CHARACTERISTICS

It's important to periodically perform a visual check of the pilot and burner flames. Compare them to the illustrations provided. If any flames appear abnormal call a service person.

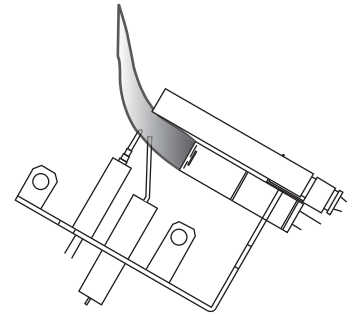

9.0 MAINTENANCE

! WARNING
TURN OFF THE GAS AND ELECTRICAL POWER BEFORE SERVICING THE APPLIANCE.
APPLIANCE MAY BE HOT, DO NOT SERVICE UNTIL APPLIANCE HAS COOLED.
DO NOT USE ABRASIVE CLEANERS.

CAUTION: Label all wires prior to disconnection when servicing controls. Wiring errors can cause improper and dangerous operation. Verify proper operation after servicing. This appliance and its venting system should be inspected before use and at least annually by a qualified service person. The appliance area must be kept clear and free of combustible materials, gasoline or other flammable vapors and liquids. The flow of combustion and ventilation air must not be obstructed.

- A. In order to properly clean the burner and pilot assembly, remove the logs, rocks and/or glass to expose both assemblies.
- B. Keep the control compartment, media, burner, air shutter opening and the area surrounding the logs clean by vacuuming or brushing, at least once a year.
- C. Check to see that all burner ports are burning. Clean out any of the ports which may not be burning or are not burning properly.
- D. Check to see that the pilot flame is large enough to engulf the flame sensor and/or thermocouple / thermopile as well as reaches the burner.
- E. Replace the cleaned logs, rocks or glass. Failure to properly position the media may cause carboning which can be distributed in the surrounding living area.
- F. Check to see that the main burner ignites completely on all openings when turned on. A 5 to 10 second total light-up period is satisfactory. If ignition takes longer, consult your local authorized dealer / distributor.
- G. Check that the gasketing on the sides, top and bottom of the door is not broken or missing. Replace if necessary.
- H. If for any reason the vent air intake system is disassembled, re-install and re-seal per the instructions provided for the initial installation.

40.1

9.1 OXYGEN DEPLETION SENSOR PILOT CLEANING

This procedure must be performed by a qualified service person!
Inspect the pilot for any visible contamination or debris (usually lint, pet hair, spider webs, carpet fibre, etc.) and remove.

Disconnect the pilot from the pilot tubing line, using a 7/16" wrench. Blow out the housing in the same direction as the gas flow. Re-install the pilot tube, turn on the gas and check for leaks.

If this does not improve the performance, replace the ODS with an exact replacement. The device is tamper resistant with no field serviceable parts.

CORRECT PILOT FLAME
(Clean, stable, pronounced blue flame).

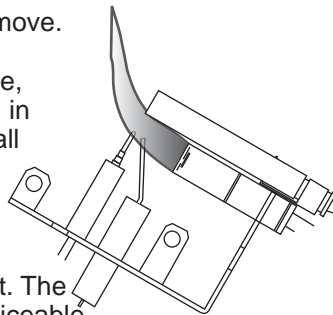

INCORRECT PILOT FLAME
(Flame lifts upwards, becomes unstable with more of an orange tip).

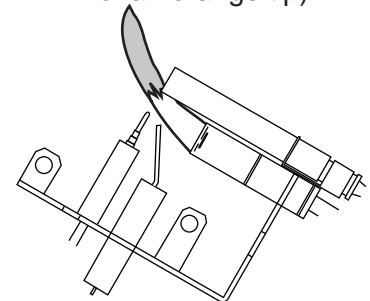

46.1

9.2 CARE OF PLATED PARTS

If the appliance is equipped with plated parts, you must clean fingerprints or other marks from the plated surfaces before operating the appliance for the first time. Use a glass cleaner or vinegar and towel to clean. If not cleaned properly before operating for the first time, the marks can cause permanent blemishes on the plating. After the plating is cured, the fingerprints and oils will not affect the finish and little maintenance is required, just wipe clean as needed. Prolonged high temperature burning with the door ajar may cause discolouration on plated parts.

NOTE: The protective wrap on plated parts is best removed when the assembly is at room temperature but this can be improved if the assembly is warmed, using a hair dryer or similar heat source.

6.1

10.0 REPLACEMENTS

Contact your dealer or the factory for questions concerning prices and policies on replacement parts. Normally all parts can be ordered through your Authorized dealer / distributor.

FOR WARRANTY REPLACEMENT PARTS, A PHOTOCOPY OF THE ORIGINAL INVOICE WILL BE REQUIRED TO HONOUR THE CLAIM.

When ordering replacement parts always give the following information:

- Model & Serial Number of appliance
- Installation date of appliance
- Part number
- Description of part
- Finish

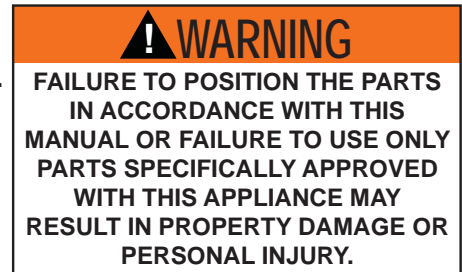

* IDENTIFIES ITEMS WHICH ARE NOT ILLUSTRATED. FOR FURTHER INFORMATION, CONTACT YOUR AUTHORIZED DEALER.

41.1

COMPONENTS		
REF	PART NO.	DESCRIPTION
1*	W357-0001	PIEZO IGNITER
2	W662-0001	NATURAL GAS OXYGEN DEPLETION SENSOR SYSTEM
2	W662-0005	PROPANE GAS OXYGEN DEPLETION SENSOR SYSTEM
3*	W680-0004	THERMOPILE
4	W725-0030	NATURAL GAS VALVE
4	W725-0031	PROPANE GAS VALVE
5*	W385-0430	CONTINENTAL LOGO
6*	GD-660	STANDARD WALL SWITCH & 20FT OF WIRE
7	GL-633	LOG SET
8*	W361-0079	GLOWING EMBERS
9*	W550-0001	CHARCOAL EMBERS
10*	W550-0002	CHARCOAL LUMPS
11*	W361-0014	VERMICULITE
12	W135-0150	BACK - LOG #1

COMPONENTS		
REF	PART NO.	DESCRIPTION
13	W135-0151	SMALL LEFT - LOG #2
14	W135-0152	SMALL RIGHT - LOG #3
15	W135-0131	LEFT CROSSOVER - LOG #4
16	W135-0132	CENTER - LOG #5
17	W135-0133	RIGHT CROSSOVER - LOG #6
18	W010-0864	PAN BURNER
19	W456-0038	#38 NATURAL GAS BURNER ORIFICE
19	W456-0053	#53 PROPANE GAS BURNER ORIFICE
20	W565-0053	CURTAIN MESH
21	W555-0038	CURTAIN ROD
22	W200-0116	SCREEN COVER
23	W655-0144	LOG SUPPORT
24	W335-0026	HOOD

ACCESSORIES		
REF	PART NO.	DESCRIPTION
25*	F60	THERMOSTATIC REMOTE
26*	W660-0013	MODULATING REMOTE
27*	GD825N	MODULATING REGULATOR - NATURAL GAS
27*	GD825P	MODULATING REGULATOR - PROPANE GAS
28*	W500-0033	VARIABLE SPEED SWITCH - WALL MOUNTING PLATE
29	GZ550-KT	BLOWER KIT
30	L42K	LOUVRE KIT - BLACK
30	L42PB	LOUVRE KIT - POLISHED BRASS
30	L42SS	LOUVRE KIT - STAINLESS STEEL

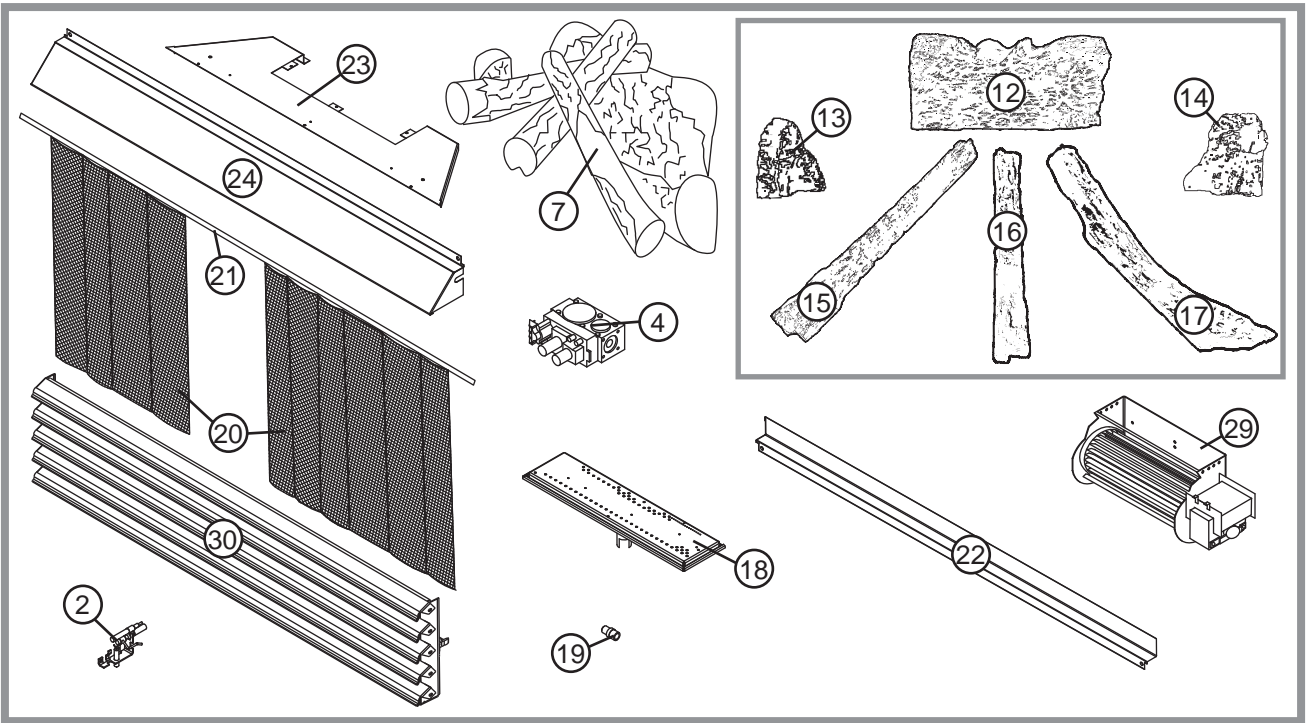

11.0 TROUBLE SHOOTING GUIDE

 WARNING		
ALWAYS LIGHT THE PILOT WHETHER FOR THE FIRST TIME OR IF THE GAS SUPPLY HAS RAN OUT, WITH THE GLASS DOOR OPEN OR REMOVED.		
TURN OFF THE GAS AND ELECTRICAL POWER BEFORE SERVICING THE APPLIANCE.		
APPLIANCE MAY BE HOT, DO NOT SERVICE UNTIL APPLIANCE HAS COOLED.		
DO NOT USE ABRASIVE CLEANERS.		
SYMPTOM	PROBLEM	TEST SOLUTION
Main burner goes out; pilot stays on.	Pilot flame is not large enough or not engulfing the thermopile.	<ul style="list-style-type: none"> - Ensure adequate supply pressure. - Replace pilot assembly.
	Thermopile shorting / loose connection.	<ul style="list-style-type: none"> - Clean thermopile connection to the valve. Reconnect. - Replace thermopile / valve.
	Remote wall switch wire is too long; too much resistance in the system.	<ul style="list-style-type: none"> - Shorten wire to connect length or wire gauge.
	Faulty thermostat or switch.	<ul style="list-style-type: none"> - Replace.
Main burner goes out; pilot goes out.	Insufficient air supply.	<ul style="list-style-type: none"> - Open window or door. (Use one of the methods described in ANSI Z223.1 / NFPA54 or the applicable local code.) - Have room checked for adequate air exchange. - See "COMBUSTION AND VENTILATION AIR PROVISIONS" section to ensure adequate air supply.
	Out of propane gas.	<ul style="list-style-type: none"> - Fill the tank.
	Pilot flame is not large enough. (Supply pressure too low.)	<ul style="list-style-type: none"> - Service or replace Oxygen Depletion Sensor System. - Correct piping and / or regulator to provide correct pressure. - Ensure adequate supply pressure.
Pilot goes out when the gas knob is released. The gas valve has an interlock device which will not allow the pilot burner to be lit until the thermocouple has cooled. Allow approximately 60 seconds for the thermocouple to cool.	System is not correctly purged.	<ul style="list-style-type: none"> - Purge the gas line.
	Out of propane gas.	<ul style="list-style-type: none"> - Fill the tank.
	Pilot flame is not large enough. (Supply pressure too low.)	<ul style="list-style-type: none"> - Service or replace Oxygen Depletion Sensor System.
	Thermocouple shorting / faulty.	<ul style="list-style-type: none"> - Loosen and tighten thermocouple. - Clean thermocouple and valve connection. - Replace Oxygen Depletion Sensor System. - Test and replace valve.
	Faulty valve / high low knob does not depress smoothly.	<ul style="list-style-type: none"> - Replace.

42.4_A

SYMPTOM	PROBLEM	TEST SOLUTION
Pilot burning; no gas to main burner; gas knob is on 'HI'; wall switch / thermostat is on.	Thermostat or switch is defective.	- Connect a jumper wire across the wall switch terminals; if main burner lights, replace switch / thermostat.
	Wall switch wiring is defective.	- Disconnect wires from valve. Connect a jumper wire across terminals 1 & 3; if the main burner lights, check the wires for defects and / or replace wires.
	Main burner orifice is plugged.	- Remove stoppage in orifice.
	Faulty valve.	- Replace.
Pilot will not light.	Out of propane gas.	- Fill the tank.
	No spark at pilot burner.	- Check if pilot can be lit by a match.
		- Check that the wire is connected to the push button ignitor.
		- Check if the push button ignitor needs tightening.
No gas at the pilot burner.	- Replace the wire if the wire insulation is broken or frayed.	
	- Replace the electrode if the ceramic insulator is cracked or broken.	
	- Replace the push button ignitor.	
Pilot goes out while standing; Main burner is in 'OFF' position.	Gas piping is undersized.	- Check that the manual valve is turned on.
		- Check the pilot orifice for blockage.
		- Replace the valve / Oxygen Depletion Sensor System.
Main burner will not light; or is slow to light, noisy pilot.	Pilot flame is not large enough.	- Call the gas distributor.
		- Turn on all gas appliances and see if pilot flame flutters, diminishes or extinguishes, especially when main burner ignites. Monitor appliance supply working pressure.
Carbon is being deposited on glass, logs, rocks, media or combustion chamber.	Air shutter has become blocked.	- Check if supply piping size is to code. Correct all undersized piping.
		- ODS Burner requires checking.
Carbon is being deposited on glass, logs, rocks, media or combustion chamber.	Flame is impinging on the glass, logs, rocks, media or combustion chamber.	- Adjust inlet pressure to ensure maximum 7.0" W.C. at gas valve for natural gas and 13.0" W.C. for propane.
		- Ensure air shutter opening is free of lint or other obstructions.
Carbon is being deposited on glass, logs, rocks, media or combustion chamber.	Flame is impinging on the glass, logs, rocks, media or combustion chamber.	- Check that the logs are correctly positioned.
		- Check for ceiling or oscillating fans that may be influencing the flame.
		- Open air shutter to increase the primary air. See "VENTURI ADJUSTMENT" section.
		- Check the input rate: check the manifold pressure and orifice size as specified by the rating plate.

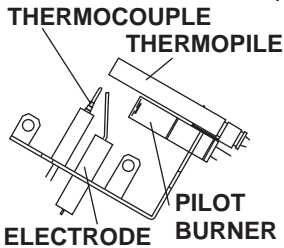

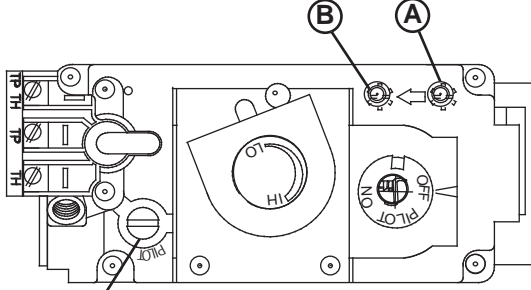
SYMPTOM	PROBLEM	TEST SOLUTION
<p>Flames are consistently too large or too small. Carboning occurs.</p>	<p>Unit is over-fired or under-fired.</p>	<ul style="list-style-type: none"> - Check pressure readings: - Inlet pressure can be checked by turning screw (A) counter-clockwise 2 or 3 turns and then placing pressure gauge tubing over the test point. Check with burner operating on "HI". Gauge should read 7" (minimum 4.5") water column for natural gas or 13" (11" minimum) water column for propane. - Outlet pressure can be checked the same as above using screw (B). Check with burner operating on "HI". Gauge should read 3.5" water column for natural gas or 10" water column for propane. - AFTER TAKING PRESSURE READINGS, BE SURE TO TURN SCREWS CLOCKWISE FIRMLY TO RESEAL. DO NOT OVER TORQUE. - Leak test with a soap and water solution.
 <p data-bbox="237 625 418 653">PILOT SCREW</p>		
<p>Air shutter improperly adjusted.</p>		
<p>Exhaust fumes smelled in room, headaches.</p>	<p>Not enough combustion air.</p>	<ul style="list-style-type: none"> - Increase fresh air supply. (Use one of the methods described in ANSI Z223.1 / NFPA 54 or the applicable local code.)
<p>Not enough ventilation air.</p>		
<p>Flame is impinging on the logs or combustion chamber.</p>		
<ul style="list-style-type: none"> - Check that the logs are correctly positioned. - Open air shutter to increase the primary air. See "VENTURI ADJUSTMENT" section. - Check the input rate: check the manifold pressure and orifice size as specified by the rating plate values. 		
<p>Remote wall switch is in "off" position; main burner comes on when gas knob is turned to "ON" position.</p>	<p>Wall switch is mounted upside down.</p>	<ul style="list-style-type: none"> - Reverse.
	<p>Remote wall switch is grounding.</p>	<ul style="list-style-type: none"> - Replace.
	<p>Remote wall switch wire is grounding.</p>	<ul style="list-style-type: none"> - Check for ground (short); repair ground or replace wire.
	<p>Faulty valve.</p>	<ul style="list-style-type: none"> - Replace.

12.0 WARRANTY

CONTINENTAL® products are manufactured under the strict Standard of the world recognized ISO 9001 : 2008 Quality Assurance Certificate.

CONTINENTAL® products are designed with superior components and materials assembled by trained craftsmen who take great pride in their work. The burner and valve assembly are leak and test-fired at a quality test station. The complete appliance is again thoroughly inspected by a qualified technician before packaging to ensure that you, the customer, receives the quality product that you expect from CONTINENTAL®.

CONTINENTAL® GAS APPLIANCE PRESIDENT'S LIFETIME LIMITED WARRANTY

The following materials and workmanship in your new CONTINENTAL® gas appliance are warranted against defects for as long as you own the appliance. This covers: combustion chamber, heat exchanger, stainless steel burner, phazer™ logs and embers, rocks, ceramic glass (thermal breakage only), gold plated parts against tarnishing, porcelainized enameled components and aluminum extrusion trims.*
Electrical (110V and millivolt) components and wearable parts such as blowers, gas valves, thermal switch, switches, wiring, remote controls, ignitor, gasketing, and pilot assembly are covered and CONTINENTAL® will provide replacement parts free of charge during the first year of the limited warranty.*
Any labour related to warranty repair is not covered.
* Construction of models vary. Warranty applies only to components included with your specific appliance.

CONDITIONS AND LIMITATIONS

CONTINENTAL® warrants its products against manufacturing defects to the original purchaser only. Registering your warranty is not necessary. Simply provide your proof of purchase along with the model and serial number to make a warranty claim. CONTINENTAL® reserves the right to have its representative inspect any product or part thereof prior to honouring any warranty claim. Provided that the purchase was made through an authorized CONTINENTAL® dealer your appliance is subject to the following conditions and limitations:
Warranty coverage begins on the date of original installation.
This factory warranty is non-transferable and may not be extended whatsoever by any of our representatives.
The gas appliance must be installed by a licensed, authorized service technician or contractor. Installation must be done in accordance with the installation instructions included with the product and all local and national building and fire codes. This limited warranty does not cover damages caused by misuse, lack of maintenance, accident, alterations, abuse or neglect and parts installed from other manufacturers will nullify this warranty. This limited warranty further does not cover any scratches, dents, corrosion or discoloring caused by excessive heat, abrasive and chemical cleaners nor chipping on porcelain enamel parts, mechanical breakage of PHAZER™ logs and embers.
CONTINENTAL® warrants its stainless steel burners against defects in workmanship and material for life, subject to the following conditions: During the first 10 years CONTINENTAL® will replace or repair the defective parts at our option free of charge. From 10 years to life, CONTINENTAL® will provide replacement burners at 50% of the current retail price.
In the first year only, this warranty extends to the repair or replacement of warranted parts which are defective in material or workmanship provided that the product has been operated in accordance with the operation instructions and under normal conditions.
After the first year, with respect to this President's Lifetime Limited Warranty, CONTINENTAL® may, at its discretion, fully discharge all obligations with respect to this warranty by refunding to the original warranted purchaser the wholesale price of any warranted but defective part(s). CONTINENTAL® will not be responsible for installation, labour or any other expenses related to the reinstallation of a warranted part and such expenses are not covered by this warranty.
Notwithstanding any provisions contained in the President's Lifetime Limited Warranty, CONTINENTAL'S responsibility under this warranty is defined as above and it shall not in any event extend to any incidental, consequential or indirect damages.
This warranty defines the obligations and liability of CONTINENTAL® with respect to the CONTINENTAL® gas appliance and any other warranties expressed or implied with respect to this product, its components or accessories are excluded.
CONTINENTAL® neither assumes, nor authorizes any third party to assume, on its behalf, any other liabilities with respect to the sale of this product. CONTINENTAL® will not be responsible for: over-firing, downdrafts, spillage caused by environmental conditions such as rooftops, buildings, nearby trees, hills, mountains, inadequate vents or ventilation, excessive venting configurations, insufficient makeup air, or negative air pressures which may or may not be caused by mechanical systems such as exhaust fans, furnaces, clothes dryers, etc.
Any damages to appliance, combustion chamber, heat exchanger, brass trim or other components due to water, weather damage, long periods of dampness, condensation, damaging chemicals or cleaners will not be the responsibility of CONTINENTAL®.
All parts replaced under the President's Limited Lifetime Warranty Policy are subject to a single claim.
During the first 10 years CONTINENTAL® will replace or repair the defective parts covered by the lifetime warranty at our discretion free of charge. From 10 years to life, CONTINENTAL® will provide replacement parts at 50% of the current retail price.
All parts replaced under the warranty will be covered for a period of 90 days from the date of their installation.
The manufacturer may require that defective parts or products be returned or that digital pictures be provided to support the claim. Returned products are to be shipped prepaid to the manufacturer for investigation. If a product is found to be defective, the manufacturer will repair or replace such defect.
Before shipping your appliance or defective components, your dealer must obtain an authorization number. Any merchandise shipped without authorization will be refused and returned to sender.
Shipping costs are not covered under this warranty.
Additional service fees may apply if you are seeking warranty service from a dealer.
Labour, travel, diagnostic tests, shipping and other related charges are not covered by this warranty.

ALL SPECIFICATIONS AND DESIGNS ARE SUBJECT TO CHANGE WITHOUT PRIOR NOTICE DUT TO ON-GOING PRODUCT IMPROVEMENTS.
CONTINENTAL® IS A REGISTERED TRADEMARK OF WOLF STEEL LTD.



Patio Heaters



Fireplace Mantels



Waterfalls



ULTRA CHEF® Grills



Electric Fireplaces



Outdoor Living Products